

TM 10-5430-258-13&P

TECHNICAL MANUAL

OPERATOR AND FIELD MAINTENANCE MANUAL INCLUDING REPAIR PARTS AND SPECIAL TOOLS LIST FOR TANK, FABRIC, COLLAPSIBLE, WATER STORAGE, 50,000 GALLON, MODEL MPC-W-50K-22636 (NSN 5430-01-486-8208)

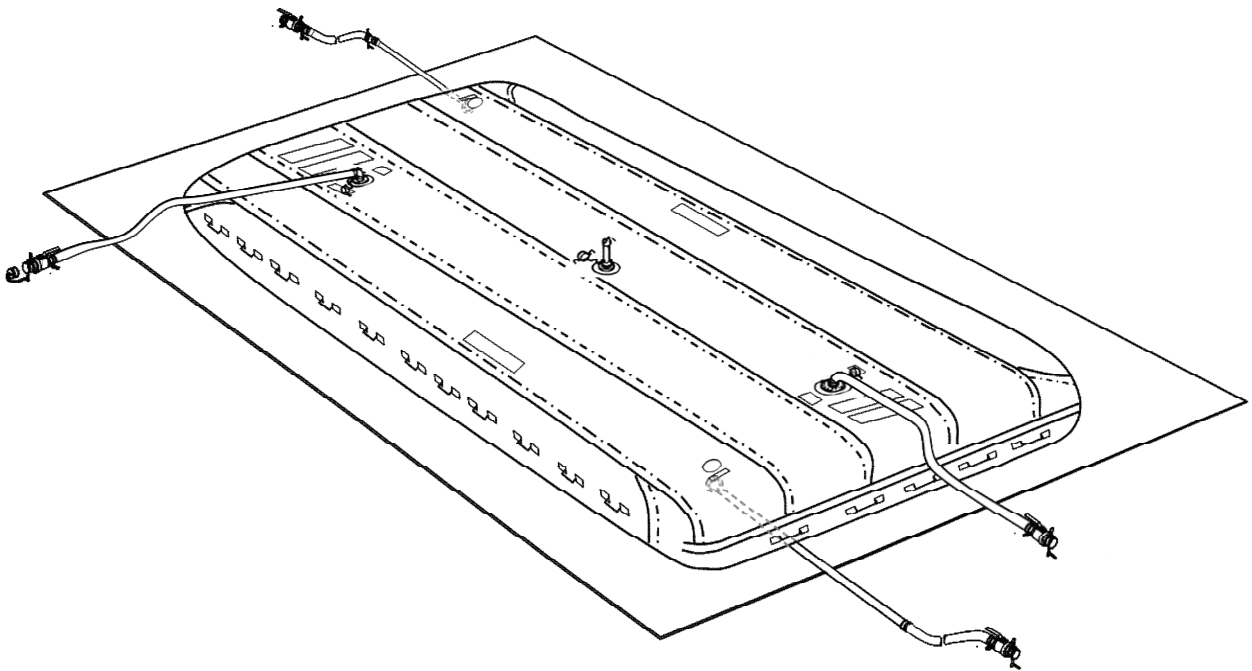

DISTRIBUTION STATEMENT A – Approved for public release; distribution is unlimited.

**HEADQUARTERS, DEPARTMENT OF THE ARMY
APRIL 2009**

WARNING SUMMARY

This warning summary contains general safety warnings and hazardous materials warnings that must be understood and applied during operation and maintenance of this equipment. Failure to observe these precautions could result in serious injury or death to personnel.

FIRST AID DATA

First aid instructions are given in FM 4-25.11, First Aid.

GENERAL SAFETY WARNINGS DESCRIPTION

WARNING

Chemical solvents used for cleaning detached Water Tank accessories, exposed fasteners, and other metallic parts (when parts have been removed from the Water Tank installation site) are flammable and toxic to skin, eyes, and the respiratory tract. Skin and eye protection are required. Use chemical solvents in a well ventilated area. Avoid prolonged breathing of solvent vapors, and minimize skin contact. Keep solvents away from excessive heat, open flame, or other sources of ignition. Solvent must not come into contact with the Water Tank fabric during any cleaning process. Solvent will contaminate water inside the Water Tank and result in illness or death.

Do not clean parts attached to the Water Tank unless solvent is 100 percent water and mild detergent mixture. Rinse all detached parts thoroughly with detergent and water before parts are reassembled on Water Tank. Wash exposed skin thoroughly. Chemical solvents used for cleaning parts are potentially dangerous to personnel.

Use Water Tank for drinking water only. Other liquids will contaminate Water Tank and could result in illness or death.

Do not overfill tank. Tank could rupture resulting in injury to personnel or death.

Make sure filler assembly coupling is installed correctly on the Water Tank or coupling may burst and cause personal injury.

Do not exceed 30 psi (206.84 kPa) when drying Water Tank. Tank could rupture resulting in injury to personnel or death.

Do not open coupling arms when water is being transferred into or out of the Water Tank. Coupling may burst and cause injury to personnel.

Do not set up the Water Tank on sloping ground. Water collecting at one end may cause it to roll over, causing injury.

Filler assembly must be tight. Under pressure, coupling may burst and cause personal injury.

The water tank is a permit required confined space. Do not enter water tank. Suffocation could result.

GENERAL SAFETY WARNINGS DESCRIPTION – CONTINUED

WARNING

Do not permit bolts, washers, gaskets, small items, dirt, or foreign matter to fall into Water Tank. Contamination could result in illness or death.

Lifting or moving Water Tanks, ground cloths, or heavy equipment incorrectly can cause serious injury. Do not lift or move more than 50 lb (22.68 kg) alone. Always get help from additional personnel during lifting operations.

CHEMICAL, BIOLOGICAL, RADIOLOGICAL, OR NUCLEAR (CBRN)

In the event equipment has been exposed to nuclear, biological or chemical warfare, the equipment shall be handled with extreme caution and decontaminated in accordance with FM 3-11.5, NBC Decontamination. Unprotected personnel can experience injury or death if residual toxic agents or radioactive material are present. If equipment is exposed to radioactive, biological, or chemical agents, personnel must wear protective mask, hood, protective overgarments, chemical gloves, and chemical boots in accordance with the Mission Oriented Protective Posture (MOPP) level prescribed by the Officer in Charge (OIC) or Non-commissioned Officer in Charge (NCOIC).

WARNING

Cold weather operations could create ice buildup on exposed surfaces producing hazardous footing conditions. Use extreme care when operating under icing conditions. Death or serious injury to personnel could occur.

LIST OF EFFECTIVE PAGES / WORK PACKAGES

NOTE: Zero in the "Change No." column indicates an original page or work package.

Date of issue for the original manual is:

Original 15 April 2009

TOTAL NUMBER OF PAGES FOR FRONT AND REAR MATTER IS 21 AND TOTAL NUMBER OF WORK PACKAGES IS 68 CONSISTING OF THE FOLLOWING:

Page / WP No.	Change No.	Page / WP No.	Change No.
Front Cover	0	WP 0034 (2 pgs)	0
Warning summary (2 pgs)	0	WP 0035 (2 pgs)	0
a/b	0	WP 0036 (2 pgs)	0
Chapter 1 title page	0	WP 0037 (2 pgs)	0
WP 0001 (4 pgs)	0	WP 0038 (4 pgs)	0
WP 0002 (6 pgs)	0	WP 0039 (4 pgs)	0
WP 0003 (2 pgs)	0	WP 0040 (2 pgs)	0
Chapter 2 title page	0	WP 0041 (4 pgs)	0
WP 0004 (2 pgs)	0	WP 0042 (4 pgs)	0
WP 0005 (18 pgs)	0	WP 0043 (4 pgs)	0
WP 0006 (6 pgs)	0	WP 0044 (2 pgs)	0
Chapter 3 title page	0	WP 0045 (2 pgs)	0
WP 0007 (2 pgs)	0	WP 0046 (2 pgs)	0
WP 0008 (2 pgs)	0	WP 0047 (2 pgs)	0
WP 0009 (2 pgs)	0	Chapter 7 title page	0
WP 0010 (2 pgs)	0	WP 0048 (6 pgs)	0
WP 0011 (2 pgs)	0	WP 0049 (4 pgs)	0
WP 0012 (2 pgs)	0	WP 0050 (4 pgs)	0
WP 0013 (2 pgs)	0	WP 0051 (4 pgs)	0
WP 0014 (2 pgs)	0	WP 0052 (4 pgs)	0
WP 0015 (2 pgs)	0	WP 0053 (4 pgs)	0
WP 0016 (2 pgs)	0	WP 0054 (4 pgs)	0
WP 0017 (2 pgs)	0	WP 0055 (4 pgs)	0
Chapter 4 title page	0	WP 0056 (4 pgs)	0
WP 0018 (2 pgs)	0	WP 0057 (4 pgs)	0
WP 0019 (6 pgs)	0	WP 0058 (4 pgs)	0
WP 0020 (2 pgs)	0	WP 0059 (4 pgs)	0
WP 0021 (2 pgs)	0	WP 0060 (2 pgs)	0
WP 0022 (2 pgs)	0	WP 0061 (2 pgs)	0
WP 0023 (2 pgs)	0	Chapter 8 title page	0
Chapter 5 title page	0	WP 0062 (2 pgs)	0
WP 0024 (2 pgs)	0	WP 0063 (4 pgs)	0
WP 0025 (2 pgs)	0	WP 0064 (2 pgs)	0
WP 0026 (2 pgs)	0	WP 0065 (8 pgs)	0
WP 0027 (2 pgs)	0	WP 0066 (2 pgs)	0
WP 0028 (2 pgs)	0	WP 0067 (2 pgs)	0
WP 0029 (2 pgs)	0	WP 0068 (2 pgs)	0
WP 0030 (2 pgs)	0		
WP 0031 (2 pgs)	0		
WP 0032 (2 pgs)	0		
Chapter 6 title page	0		
WP 0033 (2 pgs)	0		

HEADQUARTERS
DEPARTMENT OF THE ARMY
WASHINGTON, D.C., 15 APRIL 2009

TECHNICAL MANUAL
OPERATOR AND FIELD MAINTENANCE MANUAL
INCLUDING
REPAIR PARTS AND SPECIAL TOOLS LIST
FOR
TANK, FABRIC, COLLAPSIBLE, WATER STORAGE,
50,000 GALLON,
MODEL MPC-W-50K-22636
NSN 5430-01-486-8208

REPORTING ERRORS AND RECOMMENDING IMPROVEMENTS

You can help improve this publication. If you find any errors or if you would like to recommend any improvements to the procedures in this publication, please let us know. The preferred method is to submit your DA Form 2028 (Recommended Changes to Publications and Blank Forms) through the Internet on the Army Electronic Product Support (AEPS) Web site. The Internet address is <https://aeeps.ria.army.mil>. The DA Form 2028 is located under the Public Applications section on the AEPS public home page. Fill out the form and click on SUBMIT. Using this form on the AEPS site will enable us to respond to your comments quicker and to manage the DA Form 2028 program better. You may also mail, e-mail, or fax your comments or DA Form 2028 directly to the U.S. Army TACOM Life Cycle Management Command. The postal address is U.S. Army TACOM Life Cycle Management Command, ATTN: AMSTA-LC-LMPP / TECH PUBS, 1 Rock Island Arsenal, Rock Island, IL 61299-7630. The e-mail address is tacomlcmc.daform2028@us.army.mil. The fax number is DSN 793-0726 or Commercial (309) 782-0726.

TABLE OF CONTENTS

	<u>Page No.</u>	<u>WP Sequence No.</u>
List of Effective Pages.....	A	
How to Use This Manual	vi	
Chapter 1 - General Information, Equipment Description, and Theory of Operation for Tank, Fabric, Collapsible, Water Storage, 50,000 Gallon		
General Information	0001	
Equipment Description and Data	0002	
Figure 1. Tank Assembly	0002-2	
Table 1. Tank Assembly Major Components.....	0002-3	
Table 2. Tank Assembly Specifications	0002-4	
Table 3. Strapping Chart.....	0002-5	
Theory of Operation	0003	
Chapter 2 - Operator Instructions for Tank, Fabric, Collapsible, Water Storage, 50,000 Gallon		
Description and Use of Operator Controls and Indicators	0004	
Figure 1. Controls and Indicators.....	0004-1	
Table 1. Controls and Indicators	0004-1	
Operation Under Usual Conditions	0005	
Figure 1. Tank Envelope Fill Height Guideline	0005-2	
Figure 2. Shipping Container	0005-4	
Figure 3. Drain Fitting Assembly.....	0005-4	
Figure 4. Drain Ball Valve Assembly.....	0005-5	
Figure 5. Discharge Elbow Installation	0005-5	
Figure 6. Filler/Discharge Hose Assembly	0005-6	
Figure 7. Filler/Discharge Assembly	0005-6	
Figure 8. Vent Fitting Assembly	0005-7	
Figure 9. Tank Assembly	0005-10	
Figure 10. Stenciling Locations.....	0005-12	
Figure 11. Tank Assembly Components.....	0005-13	
Figure 12. Tank Folding	0005-16	
Figure 13. Tank Envelope Folding Procedures	0005-18	
Operation Under Unusual Conditions and Emergency Repair Procedures.....	0006	
Figure 1. Tank Envelope Restraining Straps	0006-2	
Figure 2. Wood Plug Installation	0006-4	

TABLE OF CONTENTS

	<u>Page No.</u>	<u>WP Sequence No.</u>
Figure 3. Installation of Mechanical Patches	0006-5	
Chapter 3 - Operator Troubleshooting Procedures for Tank, Fabric, Collapsible, Water Storage, 50,000 Gallon		
Troubleshooting Index.....	0007	
Operational Checkout	0008	
Tank Assembly Leakage.....	0009	
Vent Fitting Assembly	0010	
Filler/Discharge Assembly	0011	
Drain Fitting Assembly	0012	
Drain Hose Assembly	0013	
Drain Ball Valve Assembly	0014	
Filler/Discharge Ball Valve Assembly.....	0015	
Filler/Discharge Hose Assembly	0016	
Emergency Repair Kit.....	0017	
Chapter 4 - Operator Maintenance Instructions for Tank, Fabric, Collapsible, Water Storage, 50,000 Gallon		
Preventive Maintenance Checks and Services (PMCS) Introduction.....	0018	
Preventive Maintenance Checks and Services (PMCS) and Lubrication Procedures	0019	
Table 1. Preventive Maintenance Checks and Services (PMCS).....	0019-2	
Vent Fitting Assembly Repair.....	0020	
Figure 1. Vent Fitting Assembly	0020-1	
Filler/Discharge Assembly Repair	0021	
Figure 1. Filler/Discharge Assembly	0021-1	
Drain Ball Valve Assembly Repair	0022	
Figure 1. Drain Ball Valve Assembly.....	0022-1	
Filler/Discharge Ball Valve Assembly Repair.....	0023	
Figure 1. Filler/Discharge Ball Valve Assembly	0023-1	
Chapter 5 - Field Maintenance Troubleshooting Procedures for Tank, Fabric, Collapsible, Water Storage, 50,000 Gallon		
Troubleshooting Index.....	0024	
Tank Assembly Leakage.....	0025	

TABLE OF CONTENTS

	<u>Page No.</u>	<u>WP Sequence No.</u>
Vent Fitting Assembly	0026	0026
Filler/Discharge Assembly.....	0027	0027
Drain Fitting Assembly	0028	0028
Drain Hose Assembly.....	0029	0029
Drain Ball Valve Assembly	0030	0030
Filler/Discharge Ball Valve Assembly	0031	0031
Filler/Discharge Hose Assembly	0032	0032
Chapter 6 – Field Maintenance Instructions for Tank, Fabric, Collapsible, Water Storage, 50,000 Gallon		
Service Upon Receipt Of Materiel.....	0033	0033
Table 1. Equipment Inspection	0033-2	
Preventive Maintenance Checks and Services (PMCS) Introduction.....	0034	0034
Preventive Maintenance Checks and Services (PMCS) Procedures and Lubrication Procedures	0035	0035
Table 1. Preventive Maintenance Checks and Services (PMCS).....	0035-1	
Tank Assembly Service and Replacement	0036	0036
Figure 1. Tank Assembly	0036-1	
Tank Envelope Inspect.....	0037	0037
Vent Fitting Assembly Service and Repair.....	0038	0038
Figure 1. Vent Fitting Assembly	0038-2	
Filler/Discharge Assembly Service and Repair.....	0039	0039
Figure 1. Filler/Discharge Assembly	0039-2	
Drain Fitting Assembly Service and Repair	0040	0040
Figure 1. Drain Fitting Assembly.....	0040-1	
Drain Hose Assembly Service and Repair.....	0041	0041
Figure 1. Drain Hose Assembly	0041-1	
Figure 2. Drain Hose Assembly	0041-3	
Drain Ball Valve Assembly Service and Repair	0042	0042
Figure 1. Drain Ball Valve Assembly with Drain Hose.....	0042-1	
Figure 2. Drain Ball Valve Assembly.....	0042-2	
Figure 3. Drain Ball Valve Assembly with Drain Hose.....	0042-3	

TABLE OF CONTENTS

	<u>Page No.</u>	<u>WP Sequence No.</u>
Filler/Discharge Ball Valve Assembly Service and Repair.....		0043
Figure 1. Filler/Discharge Ball Valve and Hose Assembly.....	0043-1	
Figure 2. Filler/Discharge Ball Valve Assembly	0043-2	
Figure 3. Filler/Discharge Ball Valve Assembly with Hose	0043-4	
Filler/Discharge Hose Assembly Service and Repair		0044
Figure 1. Filler/Discharge Hose Assembly.....	0044-1	
Ground Cloth Inspect and Replacement.....		0045
Emergency Repair Kit Inspect and Replace		0046
Preparation for Storage or Shipment		0047
Chapter 7 – Parts Information for Tank, Fabric, Collapsible, Water Storage, 50,000 Gallon		
Introduction		0048
Table 1. SMR Code Explanation.....	0048-1	
GROUP 00 Tank Assembly		0049
Figure 1. Tank Assembly	0049-2	
GROUP 01 Tank Envelope.....		0050
Figure 2. Tank Envelope.....	0050-2	
GROUP 02 Vent Fitting Assembly.....		0051
Figure 3. Vent Fitting Assembly.....	0051-2	
GROUP 03 Filler/Discharge Assembly		0052
Figure 4. Filler/Discharge Assembly	0052-2	
GROUP 04 Drain Fitting Assembly.....		0053
Figure 5. Drain Fitting Assembly.....	0053-2	
GROUP 05 Drain Hose Assembly		0054
Figure 6. Drain Hose Assembly	0054-2	
GROUP 06 Drain Ball Valve Assembly.....		0055
Figure 7. Drain Ball Valve Assembly.....	0055-2	
GROUP 07 Filler/Discharge Ball Valve Assembly		0056
Figure 8. Filler/Discharge Ball Valve Assembly	0056-2	
GROUP 08 Filler/Discharge Hose Assembly.....		0057
Figure 9. Filler/Discharge Hose Assembly.....	0057-2	

TABLE OF CONTENTS

	<u>Page No.</u>	<u>WP Sequence No.</u>
GROUP 09 Ground Cloth.....		0058
Figure 10. Ground Cloth	0058-2	
GROUP 10 Emergency Repair Kit.....		0059
Figure 11. Emergency Repair Kit.....	0059-2	
National Stock Number Index		0060
Part Number Index		0061
Chapter 8 – Supporting Information for Tank, Fabric, Collapsible, Water Storage, 50,000 Gallon		
References.....		0062
Maintenance Allocation Chart (MAC) Introduction.....		0063
Maintenance Allocation Chart (MAC).....		0064
Table 1. Maintenance Allocation Chart (MAC)	0064-1	
Table 2. Tools and Test Equipment for Water Tank Assembly.....	0064-2	
Table 3. Remarks for Water Tank Assembly	0064-2	
Components of End Item (COEI) and Basic Issue Items (BII) Lists		0065
Table 1. Components of End Item (COEI) List	0065-2	
Table 2. On Board Spares	0065-6	
Table 3. Basic Issue Items (BII).....	0065-7	
Additional Authorization List (AAL)		0066
Table 1. Additional Authorization (AAL) List	0066-1	
Expendable and Durable Items List (EDIL).....		0067
Table 1. Expendable and Durable Items List (EDIL).....	0067-1	
Mandatory Replacement Parts List (MRPL)		0068
Table 1. Mandatory Replacement Parts List (MRPL).....	0068-1	
DA Form 2028		
Authentication Page		
Metric and PIN Page		

HOW TO USE THIS MANUAL

This manual contains certain features to improve the convenience of using this manual and increase the user's efficiency. These features include:

1. Accessing Information

This manual contains a Front Cover, Warning Summary, List of Effected Pages, Title Block Page, Table of Contents, Chapters 1 through 8, and an Alphabetical Index. Information is accessed by referring to Table of Contents, located in the front of this manual, or by looking in the Alphabetical Index, located in the back of the manual.

2. Illustrations

Various methods are used to locate, operate and repair or replace components. Locator illustrations in Controls and Indicator tables, PMCS tables, exploded views and cut-away diagrams make the information in the manual easier to understand and follow.

3. Using This Manual

When using this manual, read and understand the entire maintenance action before performing the task. Also, read and understand all warnings, cautions and notes, as well as general safety precautions that apply to the task to be performed. The warning summary will inform personnel of hazards associated with the equipment to be operated, maintained or repaired. However, the summary is not all-inclusive and personnel should be aware at all times of hazardous conditions that may arise.

Prior to starting the procedures in this manual, read the initial setup requirements located directly above each procedure. The information is given to ensure all materials, expendables, tools and any other equipment necessary are readily available for use. The initial setup will be accomplished prior to starting the actual steps of each operator or maintenance procedure.

LOCATING MAJOR COMPONENTS

Obtain the manual for the system to be operated, maintained or repaired. Turn to the Table of Contents located in the front of this manual. Find Chapter 1, *General Information, Equipment Description and Theory of Operation*. Under the chapter title you will find the work package titled *Equipment Description and Data* which contains *Location and Description of Major Components*. Turn to the work package indicated. The indicated work package will provide an illustration and brief description of each major components and its location.

OPERATING PROCEDURES

The Table of Contents may be used to locate operating procedures within this manual. To locate a particular operating procedure, open the manual to the Table of Contents located in the front of this manual. Locate Chapter 2, *Operator Instructions*. Under this section, locate the work package for the component you intend to operate. To the right of the operating procedure will be a work package number. Turn to the work package indicated and follow the steps to perform the procedure. The procedures indicate how to set up and operate the equipment. Follow the procedures indicated to complete the task.

At the top of the task, you will find a section entitled *INITIAL SETUP*. There are six basic headings listed under *INITIAL SETUP*.

OPERATING PROCEDURES – CONTINUED

Test Equipment: Lists all test equipment (standard or special) required to troubleshoot, test and inspect the equipment covered in this manual. The test equipment is identified with an item number and work package number from the *Maintenance Allocation Chart*, located in Chapter 8, *Supporting Information*.

Tools and Special Tools: Lists all tools (standard or special) required to perform the task. Tools are identified with an item number and work package number from the *Maintenance Allocation Chart*, located in Chapter 8, *Supporting Information*.

Materials/Parts: Lists all parts or materials necessary to perform the task. Expendable and durables are identified with an item number from the applicable work package located in Chapter 8, *Supporting Information*.

Personnel Required: Lists all personnel necessary to perform the task.

Equipment Condition: Notes the conditions that must exist before starting the task. The equipment condition will also include any prerequisite maintenance tasks to be performed with reference to the work package number or the Technical Manual (TM) number.

References: Include any other manuals necessary to complete the task. When there are no references listed, all steps necessary to complete the task are contained within this manual. A listing of reference materials is contained in the applicable work package in Chapter 8, *Supporting Information*.

TROUBLESHOOTING PROCEDURES

The Table of Contents may be used to locate sections within this manual. To locate a particular troubleshooting procedure, open the manual to the Table of Contents located in the front of this manual. Locate Chapter 3 or Chapter 5 *Troubleshooting Procedures (Operator or Field Maintenance)*. Under this section, find a work package titled *Master Malfunction/Symptom Index*. Turn to the work package indicated, which lists all troubleshooting procedures. Review the list until you find the appropriate work package for the problem you intend to solve. To the right of the procedure will be a work package number. Turn to the work package indicated and follow the steps to complete the troubleshooting procedure. Each procedure lists the malfunction, symptom and the corrective action for the problem at hand. The corrective action will indicate which maintenance procedure to refer to alleviate the symptom or what level of maintenance is capable of repairing the problem. Follow the procedures indicated to complete the task. At the top of the task, you will find a section entitled *INITIAL SETUP*. There are six basic headings listed under *INITIAL SETUP*.

Test Equipment: Lists all test equipment (standard or special) required to troubleshoot, test and inspect the equipment covered in this manual. The test equipment is identified with an item number and work package number from Table 3 of the *Maintenance Allocation Chart*, *Tools and Test Equipment*, located in Chapter 8, *Supporting Information*.

Tools: Lists all tools (standard or special) required to perform the task. Tools are identified with an item number and work package number from the *Maintenance Allocation Chart*, located in Chapter 8, *Supporting Information*.

Materials/Parts: Lists all mandatory replacement parts, expendable and durables necessary to perform the task. Expendable and durables and mandatory replacement parts are identified with an item number from the applicable work package located in Chapter 8, *Supporting Information*.

Personnel Required: Lists all personnel necessary to perform the task.

Equipment Condition: Notes the conditions that must exist before starting the task. The equipment condition will also include any prerequisite maintenance tasks to be performed with reference to the work package number or the TM number.

TROUBLESHOOTING PROCEDURES – CONTINUED

References: Include any other manuals necessary to complete the task. When there are no references listed, all steps necessary to complete the task are contained within this manual. A listing of reference materials is contained in the work package entitled *References* in Chapter 8, *Supporting Information*.

MAINTENANCE INSTRUCTIONS

To locate a maintenance procedure, open the manual to the Table of Contents located in the front of this manual. Locate the chapter, which pertains to your level of maintenance; Chapter 4 for *Operator Maintenance Instructions*, or Chapter 6 for *Field Maintenance Instructions*. Look down the list and find the maintenance procedure to be accomplished. On the right side of the maintenance procedure will be a work package number. Turn to the work package indicated. Before beginning the maintenance task, look through the procedure to familiarize yourself with the entire maintenance procedure. At the top of the task you will have a section called INITIAL SETUP. There are six basic headings listed under INITIAL SETUP.

Test Equipment: Lists all test equipment (standard or special) required to troubleshoot, test and inspect the equipment covered in this manual. The test equipment is identified with an item number and work package number from Table 2 of the Maintenance Allocation Chart, *Tools and Test Equipment*, located in Chapter 8, *Supporting Information*.

Tools: Lists all tools (standard or special) required to perform the task. Tools are identified with an item number and work package number from Table 2 of the Maintenance Allocation Chart, *Tools and Test Equipment*, located in Chapter 8, *Supporting Information*.

Materials/Parts: Lists all mandatory replacement parts, expendable and durables necessary to perform the task. Expendable and durables and mandatory replacement parts are identified with an item number from the applicable work package located in Chapter 8, *Supporting Information*.

Personnel Required: Lists all personnel necessary to perform the task.

Equipment Condition: Notes the conditions that must exist before starting the task. The equipment condition will also include any prerequisite maintenance tasks to be performed with reference to the work package number or the TM number.

References: Include any other manuals necessary to complete the task. When there are no references listed, all steps necessary to complete the task are contained within this manual. A listing of reference materials is contained in the work package entitled *References* in Chapter 8, *Supporting Information*.

REPAIR PARTS AND SPECIAL TOOLS LIST

Refer to Chapter 8, *Supporting Information* when requisitioning parts, special tools and equipment.

Identify the mandatory repair parts required to perform the task listed at the top of the work package in the INITIAL SETUP. Using the reference provided, refer to the *Mandatory Replacement Parts List* work package in Chapter 8, *Supporting Information*. Using that part number, refer to the *Part Number Index* work package in TM 10-4930-365-13&P. Look up the part number in the part number column and identify the figure and item number where the part is located. Turn to the figure and locate the item number listed. Verify that the item is correct.

CHAPTER 1

**GENERAL INFORMATION, EQUIPMENT DESCRIPTION, AND
THEORY OF OPERATION
FOR
TANK, FABRIC, COLLAPSIBLE, WATER STORAGE,
50,000 GALLON**

OPERATOR AND FIELD MAINTENANCE GENERAL INFORMATION

SCOPE

This technical manual contains instructions for operation, checks and adjustments, and corrective maintenance for the 50,000 Gallon Water Storage Collapsible Fabric Tank. The Tank Assembly provides a portable water storage system that is used to support and improve the operational readiness of Army units.

Type of Manual: Operator and Field Level Maintenance, including Repair Parts and Special Tools List.

Model Number and Equipment Name: MPC-W-50K-22636, Tank, Fabric, Collapsible, Water Storage, 50,000 Gallon.

Purpose of Equipment: The Tank Assembly is designed to store potable water only. It will store water that is off-loaded from shipping tankers or pumped from wells.

MAINTENANCE FORMS, RECORDS, AND REPORTS

Department of the Army forms and procedures used for equipment maintenance will be those prescribed by DA PAM 750-8, The Army Maintenance Management System (TAMMS) Users Manual.

REPORTING EQUIPMENT IMPROVEMENT RECOMMENDATIONS (EIRs)

If your Tank Assembly needs improvement, send us an EIR. You, the user, are the only one who can tell us what you don't like about your equipment. Let us know why you don't like the design or performance. (E-Mail: TACOM-TECH-PUBS@conus.army.mil) We will send you a reply. The preferred method for submitting Quality Deficiency Reports (QDRs) is through the Army Electronic Product Support (AEPS) Web site under the Electronic Deficiency Reporting System (EDRS). The Web address is: <https://aeprs.ria.army.mil>. If the above method is not available to you, put it on an SF 368 (Product Quality Deficiency Report) and mail it to us at: Department of the Army, U.S. Army Tank-automotive and Armaments Command, AMSRD-TAR-E, PDQR MS 268, 6501 E. 11 Mile Road, Warren, MI 38397-5000.

HAND RECEIPT (HR) MANUALS

There is no hand receipt manual for the Tank Assembly.

CORROSION PREVENTION AND CONTROL (CPC)

Corrosion prevention and control of Army materiel is a continuing concern. It is important that any corrosion problems with this item be reported so that the problem can be corrected and improvements can be made to prevent the problem in future items. While corrosion is typically associated with rusting of metals, it can also include deterioration of other materials, such as rubber and plastic. Any unusual cracking, softening, swelling, or breaking of the materials may be a corrosion problem.

If a corrosion problem is identified, it can be reported using Standard Form 368, Product Quality Deficiency Report. Use of key words such as "rust," "deterioration," "corrosion," or "cracking" will ensure that the information is identified as a CPC problem. The form should be submitted to the address specified in DA Pam 750-8.

DESTRUCTION OF ARMY MATERIEL TO PREVENT ENEMY USE

Command decisions, according to tactical situations, will determine when destruction of the Tank Assembly will be accomplished. A destruction plan will be prepared by the using organization, unless higher authority has prepared one. For general destruction procedures for this equipment, refer to TM 750-244-6, Procedures for Destruction of Tank-Automotive Equipment to Prevent Enemy Use.

PREPARATION PROCEDURES FOR STORAGE OR SHIPMENT

Army users refer to work package (WP 0046).

NOMENCLATURE CROSS-REFERENCE LIST

<u>Common Name</u>	<u>Official Nomenclature</u>
Chain	Chain, Weldless
Compression Plate	Plate, Closure, Compression
Coupling Half	Coupling Half, Quick Disconnect (Vent Fitting Assembly)
Discharge Elbow	Elbow, Quick Disconnect, Female x Male, 4-in. (10.16 cm)
Drain Bowl Fitting	Fitting, Drain Bowl 90 Deg.
Drain Hose	Hose, Fuel, 2 in. (5.08 cm) x 10 ft (3.05 m)
Drain Valve	Ball Valve, 2 in. (5.08 cm)
Dust Cap	Cap, Quick Disconnect or Cap, Dust, Quick Disconnect
Dust Plug	Plug, Dust, Quick Disconnect or Plug, Quick Disconnect
Female Coupling	Coupling Half, Quick Disconnect
Filler Elbow	Elbow, Quick Disconnect, Female x Female, 4-in. (10.16 cm)
Filler/Discharge Valve	Ball Valve, 4 in. (5.08 cm)
Flanged Adapter	Coupling Half, Quick Disconnect (Vent Fitting Assembly and Filler/Discharge Assembly)
Gasket	Gasket, Coupling 2 in. (5.08 cm)
Hose	Hose, Tan, 4 in. (10.16 cm) x 10 ft (3.05 m)
Instruction Sheet	Instruction Sheet, Type III
Key Ring	Holder, Key or Brass Ring, 1-1/2 Dia or O-Ring, Brass
Male Coupling	Coupling Half, Quick Disconnect
Mechanical Patch	Patch, Mechanical, Flexible Surface
Nut	Nut, Plain, Hexagon
Screw	Screw, Cap, Hexagon Head
Tank Assembly	Tank, Fabric, Collapsible
Tank Envelope	Tank, Fabric, Collapsible, 50K Gallon Water
Vent Cap	Vent Cap, Mushroom
Vent Pipe	Pipe, 2 in. (5.08 cm)
Washer	Washer, Flat
Blind Flange Cover	Ring, Top/Bottom

LIST OF ABBREVIATIONS/ACRONYMS

Abbreviation/Acronym	Name
AEPS	Army Electronic Product Support
AR	Army Regulation
BII	Basic Issue Items
C	Celsius
CAGEC	Commercial and Government Entity Code
CBRN	Chemical, Biological, Radiological, and Nuclear
cm	Centimeter
COEI	Components of End Item
CPC	Corrosion Prevention and Control
CTA	Common Table of Allowances
DA	Department of the Army
EDRS	Electronic Deficiency Reporting System
EIR	Equipment Improvement Recommendations
F	Fahrenheit
Fed	Federal
FGC	Functional Group Code
FM	Field Manual
ft	Foot
ft•lb	Foot-pound
gal	Gallon
GPM	Gallons per Minute
HR	Hand Receipt
Illus	Illustration
in.	Inch
in-lb	Inch-pound
JTA	Joint Table of Allowances
kg	Kilogram
kPa	Kilopascal
L	Liter
lb	Pound
LPM	Liters per Minute
MAC	Maintenance Allocation Chart
m	Meter
MOPP	Mission Oriented Protective Posture
MTOE	Modified Table of Organization and Equipment
MWO	Modification Work Order
NBC	Nuclear, Biological and Chemical
NCOIC	Non-Commissioned Officer in Charge
N•m	Newton-meter
NSN	National Stock Number
OIC	Officer in Charge
PMCS	Preventive Maintenance Checks and Services
PN	Part Number
QDR	Quality Deficiency Report
Qty	Quantity
RPSTL	Repair Parts and Special Tools List
RQR	Required
SMR	Source Maintenance and Recoverability
TAMMS	The Army Maintenance Management System
TDA	Table of Distribution and Allowances
TM	Technical Manual

LIST OF ABBREVIATIONS/ACRONYMS - CONTINUED

Abbreviation/Acronym	Name
TMDE	Test, Measurement and Diagnostic Equipment
TOE	Table of Organization and Equipment
U/M	Unit of Measure

QUALITY OF MATERIAL

Material used for replacement, repair, or modification must meet the requirements of this manual.

SAFETY, CARE, AND HANDLING

Lifting or moving heavy equipment incorrectly can cause serious injury. Do not lift or move more than 50 lb (22.68 kg) alone. Always get help from additional personnel during lifting operations.

SUPPORTING INFORMATION FOR REPAIR PARTS, SPECIAL TOOLS, TEST, MEASUREMENT AND DIAGNOSTIC EQUIPMENT (TMDE), AND SUPPORT EQUIPMENT

For authorized common tools and equipment, refer to the Modified Table of Organization and Equipment (MTOE), CTA 50-970, Expendable/Durable Items (Except: Medical, Class V, Repair Parts, and Heraldic Items), CTA 50-909, Field and Garrison Furnishings and Equipment or CTA 8-100, Army Medical Department Expendable/Durable Items, as applicable to your unit.

END OF WORK PACKAGE

**OPERATOR AND FIELD MAINTENANCE
EQUIPMENT DESCRIPTION AND DATA**

EQUIPMENT CHARACTERISTICS, CAPABILITIES, AND FEATURES

Characteristics, capabilities, and features of the Tank Assembly include:

1. The Tank Assembly is easily transportable when empty and can be set up quickly in the field. It is used primarily in quick-response deployment operations and provides long life in all climates.
2. The Tank Envelope is designed to store potable water. It will store water that is off-loaded from shipping tankers or pumped from wells. When filled, the Tank Envelope assumes a pillow shape, which causes the length and width to decrease by approximately 1 ft (30.48 cm) each, and the height to increase 4 - 5 ft (1.23 - 1.52 m).
3. The self-erecting Tank Envelope is provided with a Vent Fitting Assembly to prevent overfilling, and quick disconnect couplings and fittings to allow for rapid connection of system water hoses.
4. The Tank Envelope handles aid positioning and movement of empty Tank Envelope.
5. The Tank Assembly is compatible with all standard military water storage and handling equipment.
6. The Tank Envelope is self-supporting and does not require earth embankment support on level ground.
7. The Tank Envelope is composed of a reinforcing fabric impregnated with an elastomeric coating on both sides, which is suitable for drinking water. The materials are designed to resist exposure effects from extreme temperatures, rain, snow, ice, fungi growth, and high humidity conditions.
8. Five fittings are bonded into the Tank Envelope for attaching a Vent Fitting Assembly, two Filler/Discharge Assemblies, and two Drain Fitting Assemblies.
9. An integral Vent Fitting Assembly is located on the top center of the Tank Envelope to relieve pressure as the Tank Envelope is filled.
10. Small cuts and holes are easily repaired with the supplied Emergency Repair Kit.
11. The Tank Assembly is equipped with a Ground Cloth to protect the Tank Envelope bottom from punctures.

END OF TASK

LOCATION AND DESCRIPTION OF MAJOR COMPONENTS

This section lists major components and describes the functions of the Tank Assembly, as shown in Figure 1. Description and function of major components are contained in Table 1.

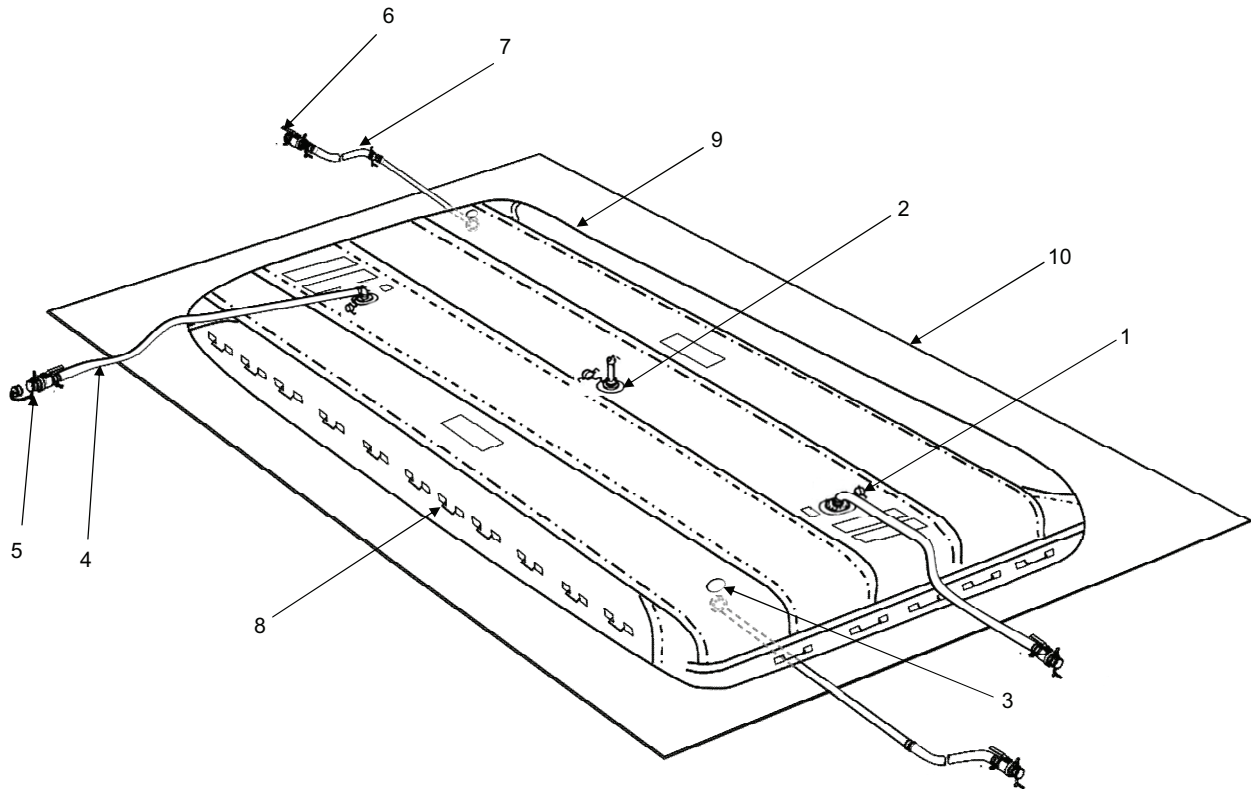

Figure 1. Tank Assembly.

LOCATION AND DESCRIPTION OF MAJOR COMPONENTS – CONTINUED
Table 1. Tank Assembly Major Components.

KEY	DESCRIPTION	FUNCTION
1	Filler/Discharge Assemblies	Provide the means to both fill and remove water from Tank Envelope. Allow Filler/Discharge Assemblies to be connected to Tank Envelope. Direct flow of water into and out of Tank Envelope through Filler/Discharge Assemblies. Can be accessed by removing Dust Caps. In two locations at opposite ends of Tank Envelope.
2	Vent Fitting Assembly	Contains mushroom-shaped Vent Cap that passively vents when internal pressure increases. Vent Cap is connected at top of Vent Pipe located in middle of Tank Envelope.
3	Drain Fitting Assemblies	Allow Drain Hose Assembly to be connected directly to Tank Envelope. Drain Fitting Assemblies are mounted on underside of Tank Envelope at each end.
4	Drain Hose Assembly	Allows water to drain from Tank Envelope. Drain Hose Assembly is comprised of a 10-ft (3.05-m) section of hose that can be attached to hand operated Drain Valve. Drain Hose Assembly is connected to Drain Fitting Assembly during installation.
5	Drain Ball Valve Assembly	Allows water to drain from Tank Envelope. Drain Valve is normally closed when Tank Envelope is not being drained or replaced.
6	Filler/Discharge Ball Valve Assembly	Allows water to flow to and from the Tank Assembly. The Filler/Discharge Valve is normally closed when the Tank Envelope is not being filled or drained.
7	Handles	Provide attachment points used to lift, move, or position the empty Tank Envelope and Ground Cloth.
8	Tank Envelope	Collapsible elastomer-coated Tank Envelope in 50,000 gal (189,270 L) capacity. Used for storage and containment of potable drinking water.
9	Ground Cloth	Spread out to protect bottom of Tank Envelope from abrasion and wear resulting from contact with ground.
10	Filler/Discharge Hose Assembly	Allows Tank Envelope to be filled and drained. Filler/Discharge Hose Assembly is comprised of a 4-in. (10.16-cm) x 10-ft (3.05-m) section of hose that can be attached to Filler/Discharge Valve.
	Emergency Repair Kit (Not Shown)	Contains items needed to perform temporary repairs of cuts and punctures to Tank Envelope.

EQUIPMENT DATA

Table 2 provides data pertaining to the operation and mechanical characteristics of components of Tank Assembly.

Table 2. Tank Assembly Specifications.

ITEM CHARACTERISTIC/SPECIFICATION	DESCRIPTION
Storage Capacity	50,000 gal (189,270 L)
Operating Temperature (Ambient)	
Low	32°F (0°C)
High	+130°F (+54.4°C)
Storage Temperature (Ambient)	
Low	-28°F (-33.4°C)
High	+160°F (+71.1°C)
Dimensions, Outside (Packaged):	
Height	45 in (114.30 cm)
Width	60 in (152.40 cm)
Length	96 in (243.84 cm)
Weight (Crated, including Ground Cloth and accessories)	2,381 lbs (1080 kg)
Dimensions (Filled)	
Height	5 ft 7 in (1.70 m) on initial fill
Length	5 ft 2 in (1.57 m) after 24 hours
Width	63 ft 8 in (19.4 m)
Dimensions (Unfolded)	
Length	23 ft 7 in (7.19 m)
Width	65 ft ± 12 in (19.81 m ± 30.48 cm)
Length	25 ft ± 12 in (7.63 m ± 30.48 cm)
Width	
Ground Cloth	
Part Number	MPC-W-50K-GC-3172
Length (Unfolded)	71 ft 6 in ± 6 in (21.79 m ± 15.24 cm)
Width (Unfolded)	30 ft 6 in ± 6 in (9.30 m ± 15.24 cm)
Weight	424 lbs (192.32 kg)

EQUIPMENT DATA - CONTINUED

Table 3 provides data pertaining to Tank Assembly strapping at initial fill and after 24 hours filled. This strapping chart is used to convert height measurements into gallons.

NOTE

This strapping chart has been developed for water at 60°F. Tank Volumes are approximate (± 5%).

Variables such as fabric stretch over time, grade or slope, where deployed, temperature, and irregularities of earthen surface will affect accuracy.

Dimensions shown are ± 1/2" except as noted.

Table 3. Strapping Chart.

Tank Height (Initial Fill)	Tank Height (Settled)	Tank Volume (gallons)	Gallons per inch to the next measurement
0'-0"	0'-0"	-	917
0'-6"	0'-5"	5,500	817
1'-0"	0'-11"	10,400	1033
1'-6"	1'-5"	16,600	633
2'-0"	1'-10"	20,400	650
2'-6"	2'-4"	24,300	683
3'-0"	2'-9"	28,400	750
3'-6"	3'-3"	32,900	700
4'-0"	3'-8"	37,100	700
4'-6"	4'-2"	41,300	683
5'-0"	4'-7"	45,400	633
5'-6"	5'-1"	49,200	800
5'-7"	5'-2"	50,000	N/A

END OF TASK

END OF WORK PACKAGE

OPERATOR AND FIELD MAINTENANCE THEORY OF OPERATION

INTRODUCTION

The Tank Assembly described in this manual is a functional component of a water distribution system. Any number of Tank Assemblies can be connected to the system, depending on operational requirements. The Tank Assembly has two operator controls. For specific operating instructions, refer to Chapter 2. The controls are:

- Filler/Discharge Valve Assembly, to control water flow during fill/discharge
- Drain Valve, to control draining

FILLING

Potable water to fill the Tank Envelope is supplied by an external water distribution system. The external system's pumps draw water from the source (e.g., tanker truck, pipeline, or purification equipment) into the Tank Envelope through the Filler/Discharge Assembly. Water flow between the supply pumps and the Tank Envelope is accomplished by opening or closing ball valves within the system supply circuit. As the Tank Envelope fills, it enlarges. When the Tank Envelope is full or no additional water is needed, supply circuit ball valves are closed. Excessive pressure caused by overfilling the Tank Envelope is relieved by the Vent Fitting Assembly. The passive Vent Cap constantly vents excess internal Tank Envelope pressure. The Filler/Discharge Valve and Filler/Discharge Hose Assembly supplied with the Water Tank Assembly can be installed on the Filler Elbow to control the Tank Envelope fill rate.

DISCHARGE

When needed, water is drawn from the Tank Envelope by the external system's suction pumps and distributed through a network of valves and hoses to the field-installed facilities. The Tank Envelope will flatten as water is drawn from it. Water flow between the external system's discharge pumps and Tank Envelope is controlled by the Filler/Discharge Valve. The Filler/Discharge Valve and Filler/Discharge Hose Assembly supplied with the Tank Assembly can be installed on the Discharge Elbow to control the Tank Envelope discharge rate, from either of the Filler/Discharge Assemblies. When the Tank Envelope is empty or no more water is needed, the downstream Filler/Discharge Valve must be closed. Venting of the Tank Envelope during discharge is not required.

DRAINING

A Drain Hose Assembly is connected to each Drain Fitting Assembly. Drain Valves attached to the Drain Hose Assembly are used to control flow from the Tank Envelope. These Drain Hose Assemblies and Drain Valves restrict flow from the Tank Envelope for sampling or complete drainage. When preparing the Tank Assembly for movement, the external system's suction pumps will draw most of the water from Tank Envelope. To ensure complete drainage, the Drain Valves are opened.

END OF WORK PACKAGE

CHAPTER 2

OPERATOR INSTRUCTIONS
FOR
TANK, FABRIC, COLLAPSIBLE, WATER STORAGE,
50,000 GALLON

OPERATOR INSTRUCTIONS
DESCRIPTION AND USE OF OPERATOR CONTROLS AND INDICATORS

INTRODUCTION

The following table and illustration provide description and use of controls and indicators pertaining to Tank Assembly.

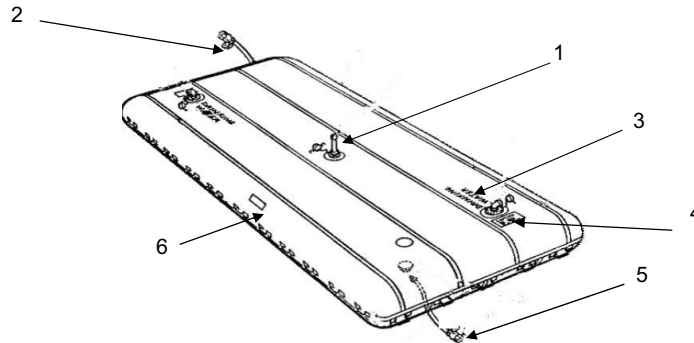

Figure 1. Controls and Indicators.

Table 1. Controls and Indicators.

Key	Control/Indicator	Function
1	Vent Fitting Assembly	Contains a mushroom-shaped Vent Cap that passively vents when internal pressure increases. Vent Cap is connected at top of Vent Pipe.
2	Drain Ball Valve Assembly	Allows water to drain from Tank Envelope. Drain Valve is normally closed when Tank Envelope is not being drained or replaced.
3	Drinking Water Label	Warns only drinking water should be put into Tank Envelope and advises contents are safe to drink.
4	Caution Label	Gives caution notice, Tank Envelope capacity, and maximum safe height.
5	Filler/Discharge Ball Valve Assembly	Allows water to flow to and from Tank Envelope. Filler/Discharge Valve is normally closed when Tank Envelope is not being filled or drained.
6	Identification Label	Tank identification giving NSN, manufacturer, date of manufacture, etc.

END OF TASK

END OF WORK PACKAGE

**OPERATOR INSTRUCTIONS
OPERATION UNDER USUAL CONDITIONS**

INITIAL SETUP:

Materials/parts

Rags, wiping (WP 0067, Item 4)
Detergent, general purpose (WP 0067, Item 2)

References

DA PAM 750-8	WP 0007
TM 10-4610-234-13	WP 0040
TB MED 577	WP 0067
WP 0006	

Personnel Required

Water Treatment Specialist 92W (4)

Equipment Condition

Drain Fitting Installed (WP0040)

SITE REQUIREMENTS

WARNING

Maximum permissible ground slope is 1 degree 21 in. (.533 m) slope in 100 ft (30.48 m)). Turbulence of water in Tank Envelope during filling or during high winds may cause it to roll and cause serious injury to personnel if placed on sloping ground.

CAUTION

Clear area of sticks, stones, heavy vegetation, and debris that can puncture or damage Tank Envelope.

NOTE

Site selection must consider where and in what configuration Tank Envelope will be used within water distribution system.

Select a site in proximity of intended usage, approximately 6 ft (1.83 m) wider and longer than flat, empty Tank Envelope size. For best operating condition, selected site should be level and should never exceed 21 in. (.533 m) of slope in 100 ft (30.48 m). If a level site cannot be obtained, Tank Envelope may be positioned with a lengthwise axis parallel to slight slope with drainage in a downhill position. In those instances when Tank Envelope is positioned across slope, it is important that it be stabilized against rolling. This can be accomplished by forming an earthen dike on downhill side, or by means of smooth timbers or sand bags. A level spot or depression may be cut in hillside to level Tank Envelope.

1. Prepare site for installation. Avoid deep irregularities that will trap liquid. Clear area of rocks, vegetation, and other items that could puncture or abrade Tank Envelope.
2. Fill all holes and depressions. Flatten and smooth ground surface.

SITE REQUIREMENTS – CONTINUED

3. Select a location that will provide enough clearance to provide for a dike. A dike is used to stop water flow in event a rupture occurs. At least a 5 ft (1.52 m) perimeter around empty Tank Envelope is needed for a service area.

NOTE

If Tank Envelope is to be used on site for a long period, a minimum of 4 in. (10.16 cm) of sand or soil should be put down before it is placed into position.

If site has a slight slope, place Drain Fitting Assembly toward lowest end (Figure 1). For best operation, ground slope should be 21 in. (.533 m) slope in 100 ft (30.48 m), not to exceed 1 degree.

When filling Tank Envelope on sloped ground, do not exceed specified full tank height.

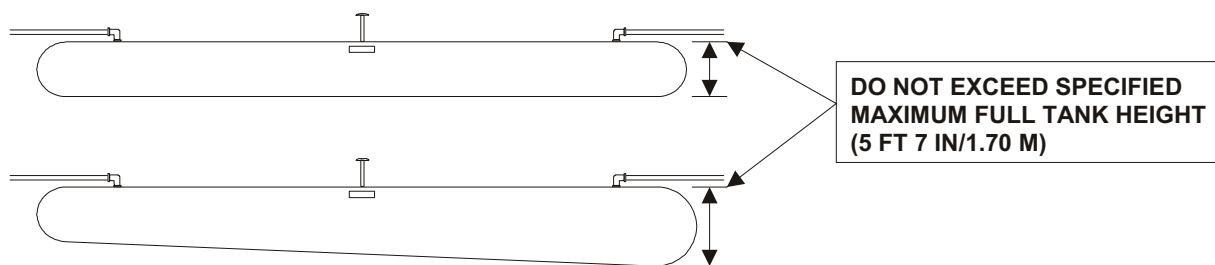

Figure 1. Tank Envelope Fill Height Guideline.

4. Cover installation site with Ground Cloth.

END OF TASK**UNPACKING EQUIPMENT****NOTE**

If Tank Assembly is part of a 40,000-gal (151,416 L) water distribution system, Tank Assembly can be packed in reusable container. Refer to TM 10-4610-234-13, Operator's, Unit and Direct Support Maintenance Manual for 40,000 Gallon Water Storage and Distribution System, for specific unpacking instructions.

If Tank Assembly is not part of a 40,000-gal (151,416 L) water distribution system, position packaged (unopened) Tank Assembly on an approved site near point of installation.

1. If Tank Assembly is received in wooden shipping crate, proceed as follows:
 - a. Cut banding straps from crate.

UNPACKING EQUIPMENT – CONTINUED

CAUTION

Remove protruding nails and other objects before attempting to remove Tank Assembly from container. This is necessary to avoid puncturing Tank Envelope.

- b. Carefully open shipping container by removing nails and bolts from container lid, retaining boards, container sides, and ends.
- c. Remove hoses, items in partition, and packing material.

CAUTION

When removing Tank Envelope from shipping container, lifting device must have a minimum capacity of 2,500 lb (1,133.98 kg). This is necessary to avoid damage to equipment and Tank Envelope.

- d. Locate Lifting Slings and position around Tank Envelope. Insert suitable lifting device (2,500 lb/1,135 kg minimum capacity) through loops of Lifting Slings.
- e. Use lifting device, and Lifting Slings to remove Tank Envelope from crate.
- f. Transport Tank Envelope to center of desired installation site.
- g. Cover installation site with Ground Cloth.

NOTE

If Tank Envelope is being replaced, package unserviceable Tank Envelope in empty container in same manner that new Tank Envelope is packaged.

- 2. Verify contents of shipping container, using packing list as a checklist. Report all discrepancies in accordance with DA PAM 750-8.

NOTE

Items inside crate are listed sequentially from top to bottom (Figure 2 shows configuration of shipping container):

<u>ITEM</u>	<u>QUANTITY</u>
Hose Assemblies	4 each
Lifting Slings	2 each
Tank Envelope	1 each
Partition containing accessories, quick disconnect fittings, packing list, and Emergency Repair Kit	1 each

UNPACKING EQUIPMENT – CONTINUED

Figure 2. Shipping Container.

3. Unwrap and inspect equipment for damage incurred during shipment.
4. Verify that equipment has not been modified.
5. Remove protective compounds such as waxed paper, waterproof tape, and barrier material. Remove preservatives and greases from unpainted, threaded, and exposed surfaces.

END OF TASK**ASSEMBLY AND PREPARATION FOR USE****Drain Fitting Assembly**

1. Fold back Tank Envelope to expose Drain Fitting Assembly. Dig a shallow trench in ground from Drain Fitting Assembly to outer edge of Tank Envelope to house Drain Fitting Assembly and Drain Hose Assembly. If Tank Envelope is positioned on hard ground, make a bed of sand or soft soil to support Drain Fitting Assembly and Drain Hose Assembly. This will alleviate stress on fabric when Tank Envelope is filled with water. Trench must allow free drainage when Tank Envelope is emptied and folded for repacking.
2. Verify Drain Fitting (Figure 3, Item 1) has been properly installed (WP 0040).
3. Install the Drain Hose (Figure 3, Item 2) to the Drain Bowl Fitting (Figure 3, Item 1). Connect female coupling of Drain Hose (Figure 3, Item 2) to male coupling of Drain Bowl Fitting (Figure 3, Item 1). Ensure gasket is in place and not damaged (Figure 3, Item 3).

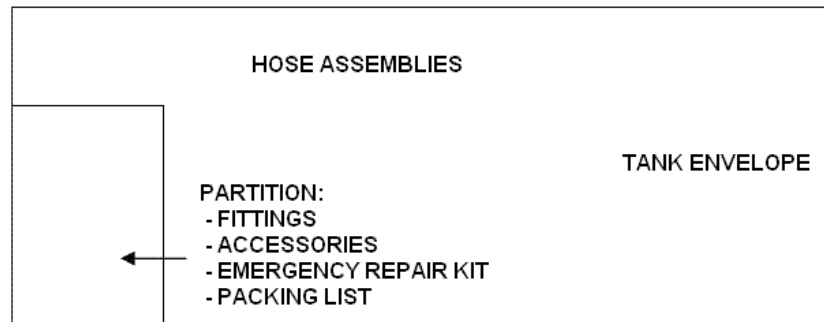
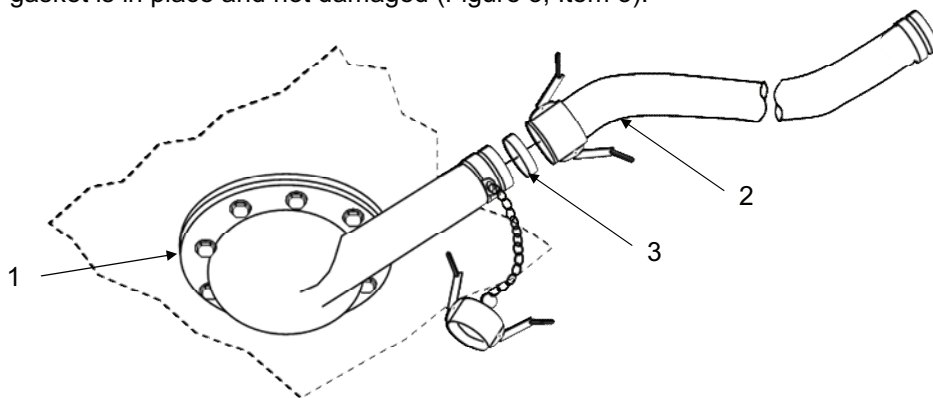

Figure 3. Drain Fitting Assembly.

ASSEMBLY AND PREPARATION FOR USE – CONTINUED

4. Place Drain Hose into prepared trench and return Tank Envelope to its normal flat position.
5. Install the Drain Ball Valve Assembly (Figure 4, Item 1). Connect female coupling of Drain Valve (Figure 4, Item 1) to male coupling of Drain Hose (Figure 4, Item 2). Clamp into position using cam-lever arms (Figure 4, Item 3).
6. Ensure Drain Valve (Figure 4, Item 1) lever is closed.

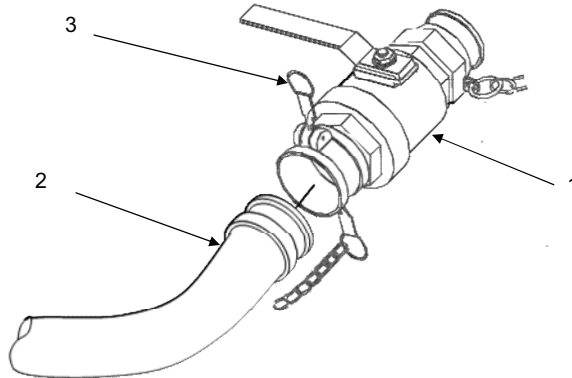

Figure 4. Drain Ball Valve Assembly.

Filler/Discharge Assembly (Discharge Elbow)

1. Remove Dust Cap (Figure 5, Item 2) from Flanged Adapter (Figure 5, Item 3).

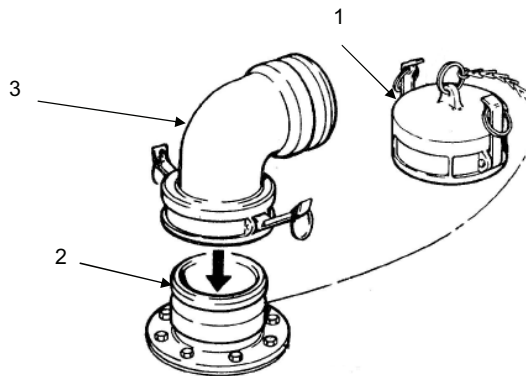

Figure 5. Discharge Elbow Installation.

2. Install Discharge Elbow (Figure 5, Item 1) onto Flanged Adapter (Figure 5, Item 3). Clamp into position using cam-lever arms, and point male part of Discharge Elbow (Figure 5, Item 1) in direction Filler/Discharge Hose Assembly will lie (Figure 6).

ASSEMBLY AND PREPARATION FOR USE – CONTINUED

3. Push Filler/Discharge Hose Assembly (Figure 6, Item 1) onto Discharge Elbow (Figure 6, Item 2). Push cam-lever arms into position.

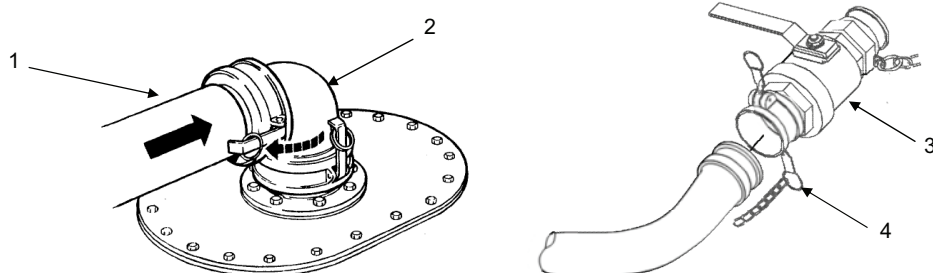

Figure 6. Filler/Discharge Hose Assembly.

4. Place male end of Filler/Discharge Hose Assembly (Figure 6, Item 1) into Female Coupling of Filler/Discharge Valve (Figure 6, Item 3).
5. Lock Filler/Discharge Hose Assembly in place using cam-lever arms (Figure 6, Item 4).

NOTE

Filler/Discharge Valve is fully opened by rotating handle until handle is parallel to valve body.

Filler/Discharge Valve is fully closed by rotating handle until handle is perpendicular to valve body.

Filler/Discharge Assembly (Filler Elbow)

1. Remove Dust Cap (Figure 7, Item 1) from Flanged Adapter (Figure 7, Item 2).

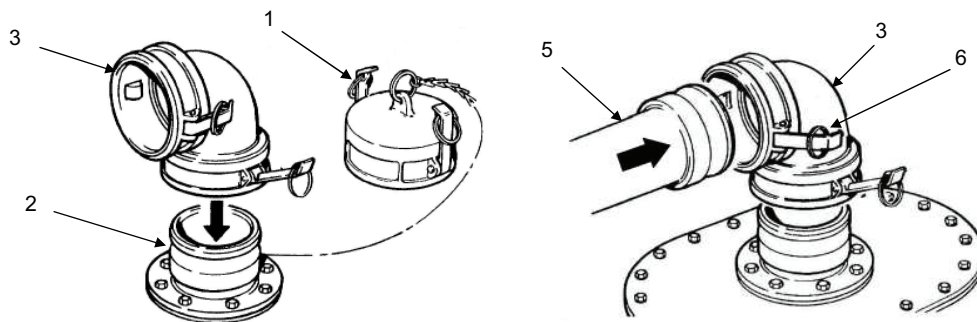

Figure 7. Filler/Discharge Assembly.

ASSEMBLY AND PREPARATION FOR USE – CONTINUED**WARNING**

Ensure Filler Elbow (Figure 7, Item 3) is correctly attached to Flanged Adapter (Figure 7, Item 2) and Filler/Discharge Hose Assembly (Figure 7, Item 5). If improperly installed, pressure buildup during filling could cause fittings to fly apart and cause injury.

2. Install Filler Elbow (Figure 7, Item 3) onto Flanged Adapter (Figure 7, Item 2). Position it in direction Filler/Discharge Hose Assembly will lie and clamp using cam-lever arms.
3. Push Filler/Discharge Hose Assembly onto Filler Elbow (Figure 7, Item 3). Push cam-lever arms into position (Figure 7, Item 6).
4. Place female end of Filler/Discharge Hose Assembly into Male Coupling of Filler/Discharge Valve (Figure 6, Item 3).
5. Push Filler/Discharge Assembly cam-lever arms into position to lock Filler/Discharge Hose Assembly in place (Figure 6, Item 4).

NOTE

Filler/Discharge Valve is fully opened by rotating handle until handle is parallel to valve body.

Filler/Discharge Valve is fully closed by rotating handle until handle is perpendicular to valve body.

Vent Fitting Assembly

1. Remove Dust Cap (Figure 8, Item 1) from Flanged Adapter (Figure 8, Item 5) and clamp Coupling (Figure 8, Item 2) in place.

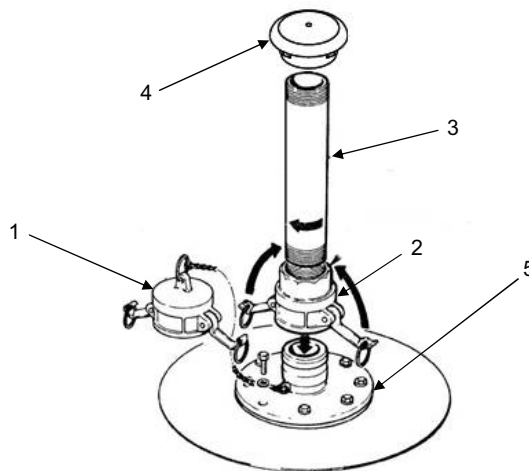

Figure 8. Vent Fitting Assembly.

2. Install Vent Pipe (Figure 8, Item 3) by hand-tightening.
3. Install Vent Cap (Figure 8, Item 4) by hand-tightening.

END OF TASK

OPERATING PROCEDURES

NOTE

Tank Assembly has two operator controls. For specific operating instructions, refer to Chapter 2. The controls are:

- Filler/Discharge Valve (Figure 9, Item 5), to control water flow during fill/discharge
- Drain Valve (Figure 9, Item 2), to control draining

Initial Adjustments and Routine Checks

1. Check for leaks.
2. If Tank Envelope is cut or punctured during any phase of operation, refer to WP 0006 for emergency repair procedures.
3. Tighten any loose components. Refer to WP 0007 for operator troubleshooting procedures.

Filling Tank Envelope

CAUTION

Do not allow Filler/Discharge Hose Assemblies to strain Tank Envelope fabric during operation. If necessary, support each Filler/Discharge Hose to prevent stress on Tank Envelope fabric.

Personnel operating Tank Envelope must periodically check dates on data plates to verify that Tank Envelope is safe for use. Shelf storage life is 12 years from date of manufacture. Tank Envelope showing signs of deterioration should not be placed in operation. Failure to heed caution could result in Tank Envelope rupture causing damage to and loss of government property.

NOTE

Either Filler/Discharge Assembly (Figure 9, Items 3 and 6) can be used as fill or discharge port.

1. After performing adjustments and routine checks, attach water source to Filler/Discharge Valve (Figure 9, Item 5).
2. Close Drain Valve (Figure 9, Item 2).
3. Check Vent Fitting Assembly (Figure 9, Item 1) installation to ensure Vent Cap (Figure 9, Item 7) is not plugged.
4. Water may be introduced into Tank Envelope by several means. Two recommended methods follow:
 - a. With Vent Fitting Assembly (Figure 9, Item 1) in place, water may be introduced into Tank Envelope through Filler/Discharge Valve (Figure 9, Item 5) until fluid reaches specified height (3 in./7.62 cm) in Vent Fitting Assembly (Figure 9, Item 1), but not to exceed maximum specified filled Tank Envelope height (5.6 ft/1.71 m).
 - b. Water may be metered into collapsed Tank Envelope through Filler/Discharge Valve (Figure 9, Item 5) by means of a gravity head or by pumping.
5. Activate water source.

OPERATING PROCEDURES – CONTINUED**CAUTION**

Do not exceed noted capacity of Tank Envelope when filling. If a metering gauge is not available at time of filling, do not exceed specified maximum filled Tank Envelope height (5.6 ft/1.71 m). Tank Envelope will burst if it becomes overfilled, causing damage to equipment.

6. Open Filler/Discharge Valve (Figure 9, Item 5) and begin filling Tank Envelope. Maximum fill rate is 350 GPM (1,325 LPM).
7. Fill Tank Envelope with 2,000 gal (7,571 L) of water. Observe Tank Envelope body, fittings, and Vent Fitting Assembly (Figure 9, Item 1) during filling operations to ensure they are secure and not leaking. Reseat couplings if they leak.
8. Report all leaks immediately to local supervisor. If no leaks are found, fill Tank Envelope to noted capacity.
9. Close Filler/Discharge Valve (Figure 9, Item 5) when Tank Envelope is full.
10. Deactivate water source.
11. Disconnect water source from Filler/Discharge Valve (Figure 9, Item 5).

Discharging Tank Envelope

1. Inspect Tank Envelope to verify it is set up correctly.

NOTE

Use Discharge Elbow (Figure 9, Items 6) for this operation.

2. Verify Drain Valve (Figure 9, Item 2) is closed.
3. Attach an emptying source (water distribution system discharge water pump) to Filler/Discharge Valve (Figure 9, Item 5).
4. Open Filler/Discharge Valve (Figure 9, Item 5) if installed on Discharge Elbow (Figure 9, Item 4).

OPERATING PROCEDURES – CONTINUED

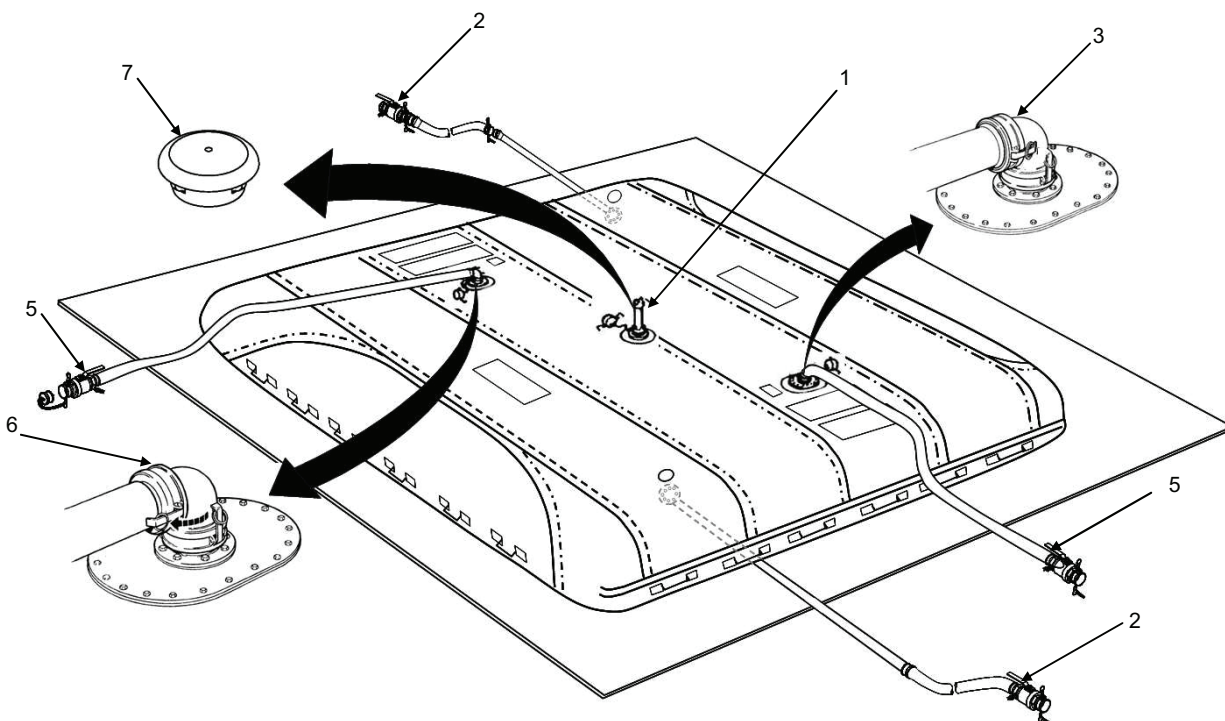

Figure 9. Tank Assembly.

5. If ball valve is installed on Filler Elbow (Figure 9, Item 3), close Filler/Discharge Valve (Figure 9, Item 5).
6. Open external water system discharge ball valve.
7. Start external water system discharge (suction) water pumps.
8. Allow water to flow from Tank Envelope until required amount is discharged.
9. If ball valve is installed on Discharge Elbow (Figure 9, Item 6), close Filler/Discharge Valve (Figure 9, Item 5).
10. Close external water system discharge ball valve.
11. Disconnect Filler/Discharge Hose Assembly from Discharge Elbow (Figure 9, Item 6), if attached.
12. Open Drain Valve (Figure 9, Item 2) to allow remaining water to drain from Tank Envelope.
13. Close Drain Valve (Figure 9, Item 2) when Tank Envelope is empty by rotating handle clockwise.

Operation of Auxiliary Equipment

No auxiliary equipment is provided with Tank Assembly.

END OF TASK

DECALS AND DATA PLATES**NOTE**

Stenciled markings are used on Tank Envelope to advise operator of proper operating procedures. Stenciling provides additional operating information and cautions to be observed during use of equipment. Figure 10 shows examples of stenciling on Tank Envelope.

Permanent stenciling has replaced decals on Tank Envelope, as noted below:

- Identification Stenciling. Tank Envelope is marked with identification stenciling, which lists the following:
 - TANK, FABRIC, COLLAPSIBLE:
 - (50,000 GALLONS) DRINKING WATER
 - NSN:
 - MANUFACTURER:
 - MANUFACTURE DATE:
 - CONTRACT NO.:
 - LOT & SERIAL NO.:
 - WEIGHT EMPTY:
 - CRATED WEIGHT:
- Torque Requirement Stenciling. The following information regarding torque requirements is stenciled adjacent to each fitting assembly:

MAXIMUM TORQUE

11 ft•lb

DECALS AND DATA PLATES – CONTINUED

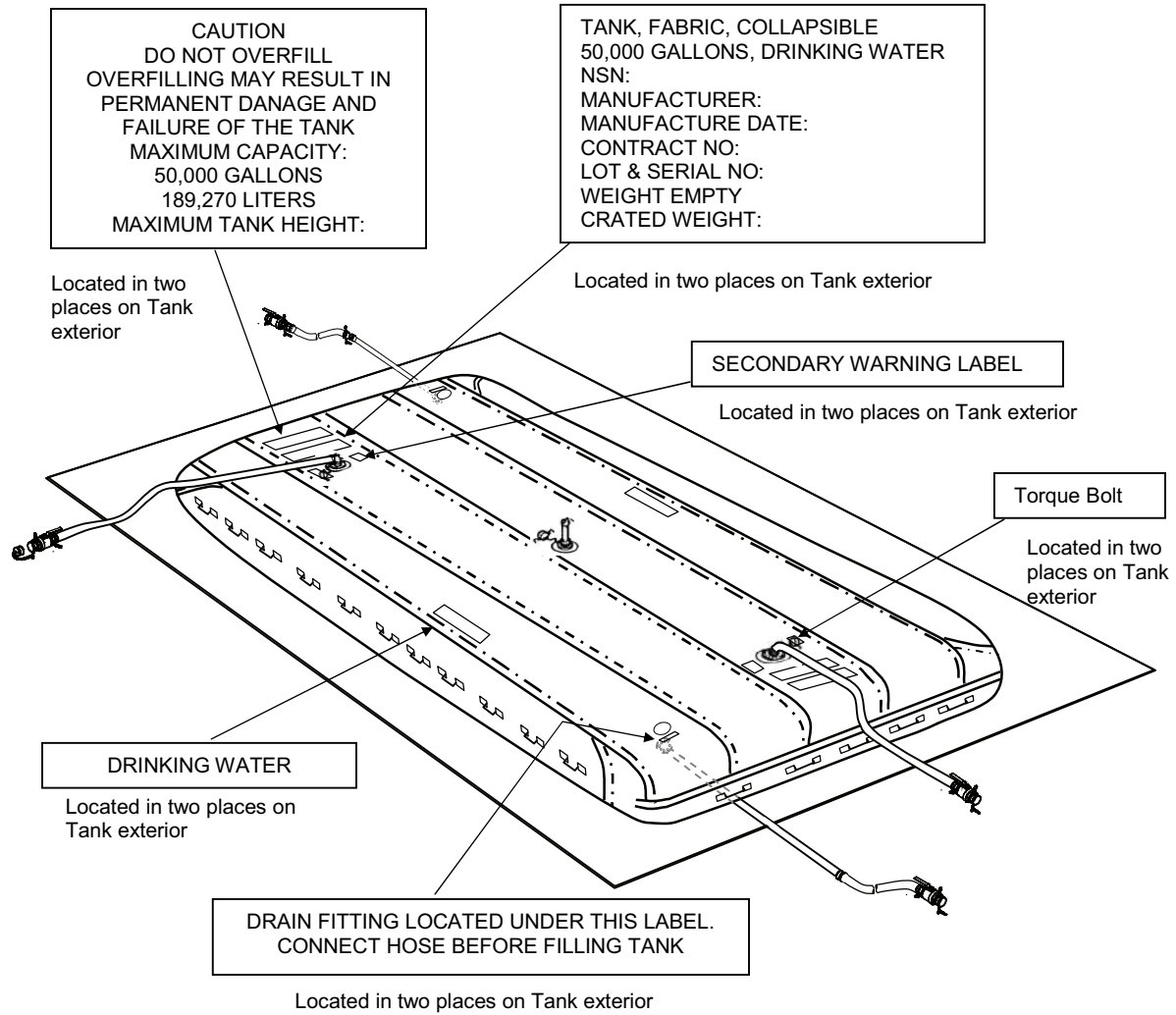

Figure 10. Stenciling Locations.

END OF TASK

PREPARATION FOR MOVEMENT

Draining, Disassembling, and Exterior Tank Envelope Cleaning

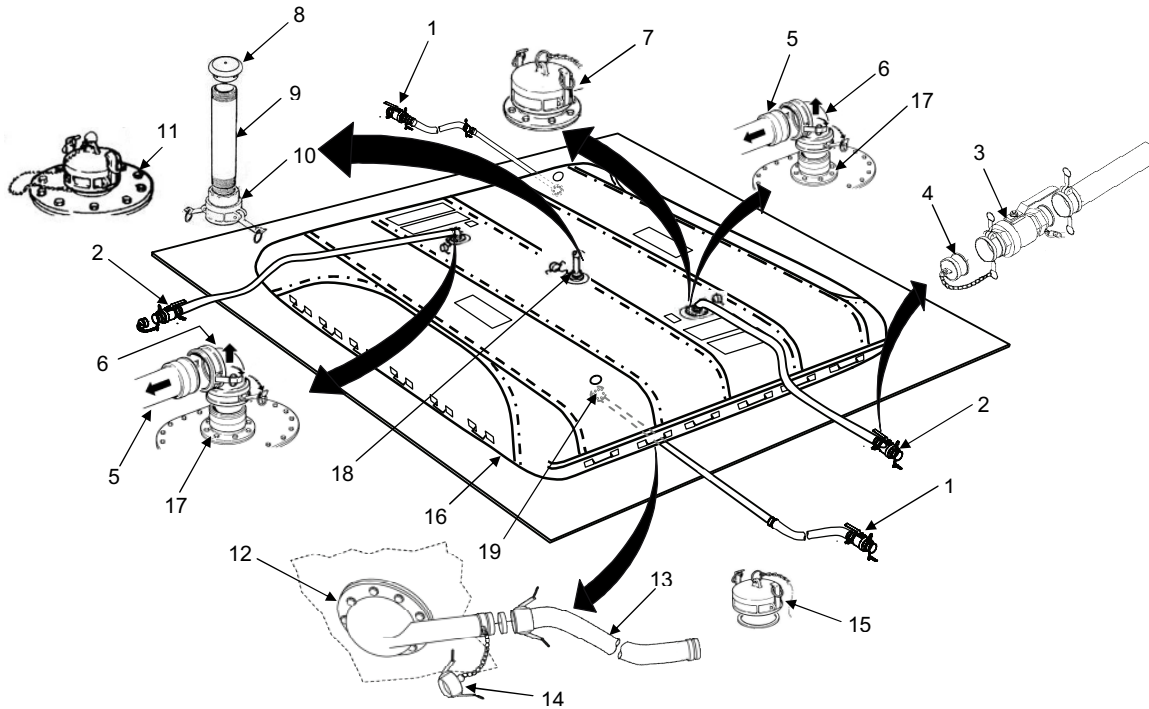

Figure 11. Tank Assembly Components.

1. Open Drain Valves (Figure 11, Item 1) to drain water from Tank Envelope (Figure 11, Item, 16).

WARNING

Four personnel are required to handle and fold Tank Envelope (Figure 11, Item, 16) during draining and disassembly. Failure to comply with this warning could cause serious injury to personnel.

2. Open Filler/Discharge Valves (Figure 11, Item 2) to drain water from Filler/Discharge Hose Assemblies (Figure 11, Item 5).
3. Remove Filler/Discharge Valves (Figure 11, Item 2) from Filler/Discharge Hose Assemblies (Figure 11, Item 5).
4. Install Dust Caps (Figure 11, Item 15) and Dust Plugs (Figure 11, Item 4) on Filler/Discharge Valves (Figure 11, Item 3).
5. Remove Filler/Discharge Hose Assemblies (Figure 11, Item 5) from Filler/Discharge Elbows (Figure 11, Item 6).
6. Place Dust Caps (Figure 11, Item 15) and Dust Plugs (Figure 11, Item 4) on Filler/Discharge Hose Assemblies (Figure 11, Item 5).
7. Remove Filler/Discharge Elbows (Figure 11, Item 6).

PREPARATION FOR MOVEMENT – CONTINUED**Draining, Disassembling, and Exterior Tank Envelope Cleaning - CONTINUED**

8. Place Dust Caps (Figure 11, Item 7) on Flanged Adapters (Figure 11, Item 17).
9. Remove Vent Cap (Figure 11, Item 8).
10. Remove Vent Pipe (Figure 11, Item 9).
11. Remove Coupling Half (Figure 11, Item 10).
12. Install Dust Cap (Figure 11, Item 11) on Flanged Adaptor (Figure 11, Item 11) of Vent Fitting Assembly (Figure 11, Item 18).
13. Lift ends of Tank Envelope (Figure 11, Item, 16) to locate Drain Fitting Assemblies (Figure 11, Item 12).
14. Drain remaining water from Tank Envelope (Figure 11, Item, 16) by rolling Tank Envelope (Figure 11, Item, 16) edges toward center while squeezing water toward Drain Fitting Assemblies (Figure 11, Item 19).
15. Disconnect Drain Valves (Figure 11, Item 1) from Drain Hose Assemblies (Figure 11, Item 13).
16. Install Dust Caps (Figure 11, Item 15) and Dust Plugs (Figure 11, Item 4) on Drain Valves (Figure 11, Item 1).
17. Install Dust Plugs (Figure 11, Item 4) on Drain Hose Assemblies (Figure 11, Item 13).
18. Remove Drain Hose Assemblies (Figure 11, Item 13).
19. Install Dust Plugs (Figure 11, Item 4) on Drain Hose Assemblies (Figure 11, Item 13).
20. Install Dust Caps (Figure 11, Item 14) on Drain Bowl Fittings (Figure 11, Item 12).
21. Clean outside surfaces of components with general purpose detergent (WP 0067, Item 2) and warm water solution.
22. Rinse thoroughly with clean water.
23. Allow components to dry completely.

Cleaning Tank Interior**NOTE**

Tank Envelope interior requires little cleaning and should be cleaned only if required. If Tank Envelope requires interior cleaning and is part of water distribution system, close and disconnect distribution links.

1. Fill Tank Envelope with approximately 300 gal (1136 L) of water and add one gallon of general purpose detergent (WP 0067, Item 2) by pouring it into Vent Fitting Assembly.
2. Close all openings and splash general purpose detergent (WP 0067, Item 2) solution back and forth by alternately pulling ends of Tank Envelope over top of Tank Envelope.
3. Drain general purpose detergent (WP 0067, Item 2) solution from Tank Envelope and flush with clean water.
4. Repeat flushing as necessary and allow Tank Envelope to air dry.
5. Sanitize the Tank Envelope using procedures outlined in TB Med 577.

PREPARATION FOR MOVEMENT – CONTINUED**Cleaning Tank Interior – CONTINUED**

6. Clean all components with general purpose detergent (WP 0067, Item 2) and warm water solution, rinse thoroughly in water, and dry with wiping rags (WP 0067, Item 4).

END OF TASK**PACKING AND FOLDING INSTRUCTIONS****WARNING**

Four personnel are required to handle and fold Tank Envelope during draining and disassembly. Failure to comply with this warning could cause serious injury to personnel.

CAUTION

Make sure Tank Envelope is completely dry before folding to prevent mildew, which can decrease life of Tank Envelope.

Throughout folding process, brush stones, grass, and other debris from Tank Envelope and Ground Cloth to avoid punctures or tears.

1. Remove Dust Cap (Figure 12, Item 1) from Flanged Adapter (Figure 12, Item 2) on Tank Envelope (Figure 12, Item 3).
2. Working from sides of Tank Envelope (Figure 12, Item 3), tightly fold both sides toward center of Tank Envelope and stop at vent fitting (Figure 12, Item 2).
3. Brush stones, dirt, twigs, and debris from Tank Envelope (Figure 12, Item 3).
4. Tightly fold both sides towards center of Tank Envelope (Figure 12, Item 3).
5. Roll Tank Envelope (Figure 12, Item 3) ends toward Flanged Adapter (Figure 12, Item 2).
6. Place two Lifting Slings (Figure 12, Item 4) around Tank Envelope (Figure 12, Item 3).
7. Remove rolled Tank Envelope (Figure 12, Item 3) from Ground Cloth (Figure 12, Item 5).

PREPARATION FOR MOVEMENT – CONTINUED**Packing and Folding Instructions – CONTINUED**

Figure 12. Folding Tank Envelope.

Packing Tank in Standardized Container

1. Lower folded Tank Envelope into shipping container from backside of container, with markings and address label on front side of container. Tank Envelope should be flush with front edge of container, leaving a 4-in. (10.16-cm) gap in back, into which Hose Assemblies will be placed.
2. Install Dust Cap on Flanged Adapter.
3. Repack and store accessories in shipping container.
4. Fold Ground Cloth into bundle and place into container. Store Ground Cloth in partition.

PREPARATION FOR MOVEMENT – CONTINUED**Packing in a Reusable Container**

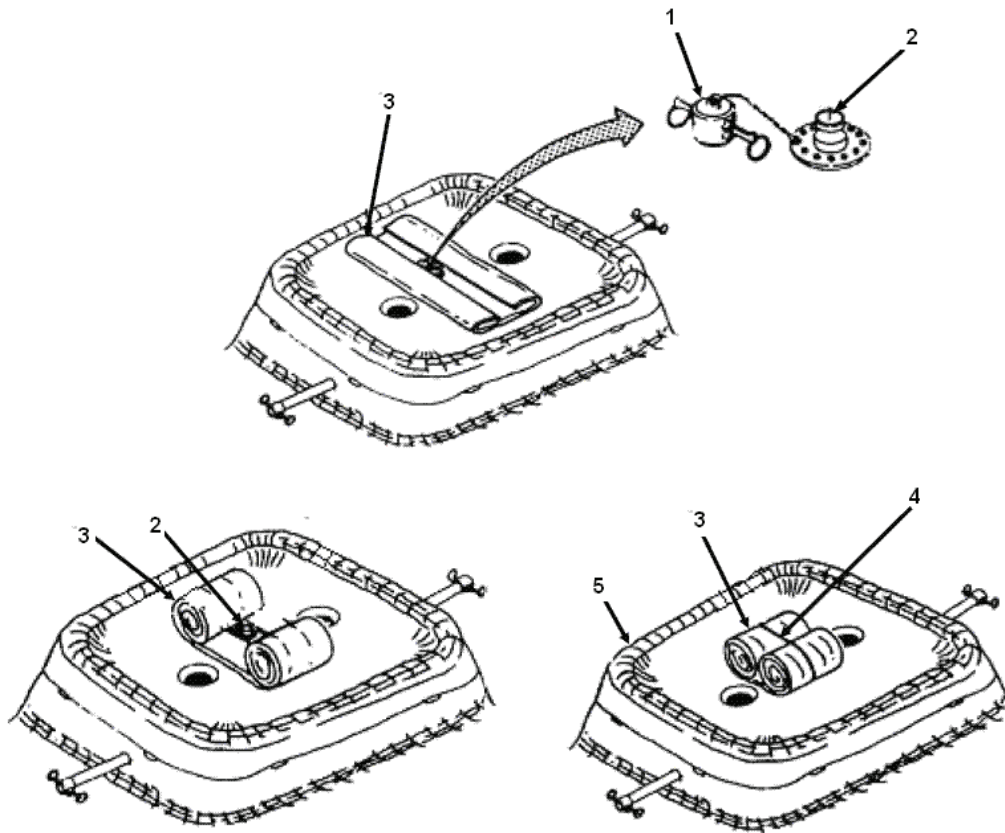
If Tank Envelope is supplied as part of 40,000 Gallon Water Storage and Distribution System, refer to TM 10-4610-234-13, Operator's Unit and Direct Support Maintenance Manual for 40,000 Gallon Water Storage and Distribution System, for instructions on packing Tank Envelope in reusable container.

END OF TASK**Alternate Packing and Folding Instructions (Repacking In Shipping Container)**

1. Remove camlock dust caps, chains, plugs, hoses, and any other quick disconnect fittings from the Tank and cushion and place them next to the shipping container.
2. Each tank port is furnished with an installed chafing panel. Unfold the chafing panel over the male flanged adapter and secure to the tank with the straps attached to the tank.

NOTE

As the tank is folded air will exhaust slowly through the obstructed, but open tank ports. Allow ample time (Ten minutes) to completely exhaust the air while rolling.

3. Working from either side of Tank Envelope (Figure 13, Item 1), lift the long edge and tightly fold towards center of Tank Envelope (Figure 13, Item 2) and stop 20 inches beyond Tank Envelope centerline (Figure 13, Item 3). Brush away stones, dirt, twigs and debris on Tank Envelope fabric.
4. Lift the opposite long edge and tightly fold Tank Envelope towards center, overlapping the first fold and stopping approximately 31 inches from the folded outer edge of the Tank Envelope (Figure 13, Item 4). Brush away stones, dirt, twigs and debris on Tank Envelope fabric.
5. Starting at either end, roll Tank Envelope (Figure 13, Item 5) end toward opposite end. The maximum roll starting width is 122 inches. Control the roll width ensuring that roll width does not exceed 130 inches. This will ensure that the tank envelope will fit inside the reusable shipping container.
6. Place two Lifting Slings around Tank Envelope (Figure 13, Item 5).

NOTE

It is best to let the final roll sit awhile before placing in box, to allow air to exhaust completely.

7. Remove rolled Tank Envelope (Figure 13, Item 5) from berm (Figure 13, Item 6) and place in shipping container.

PREPARATION FOR MOVEMENT – CONTINUED

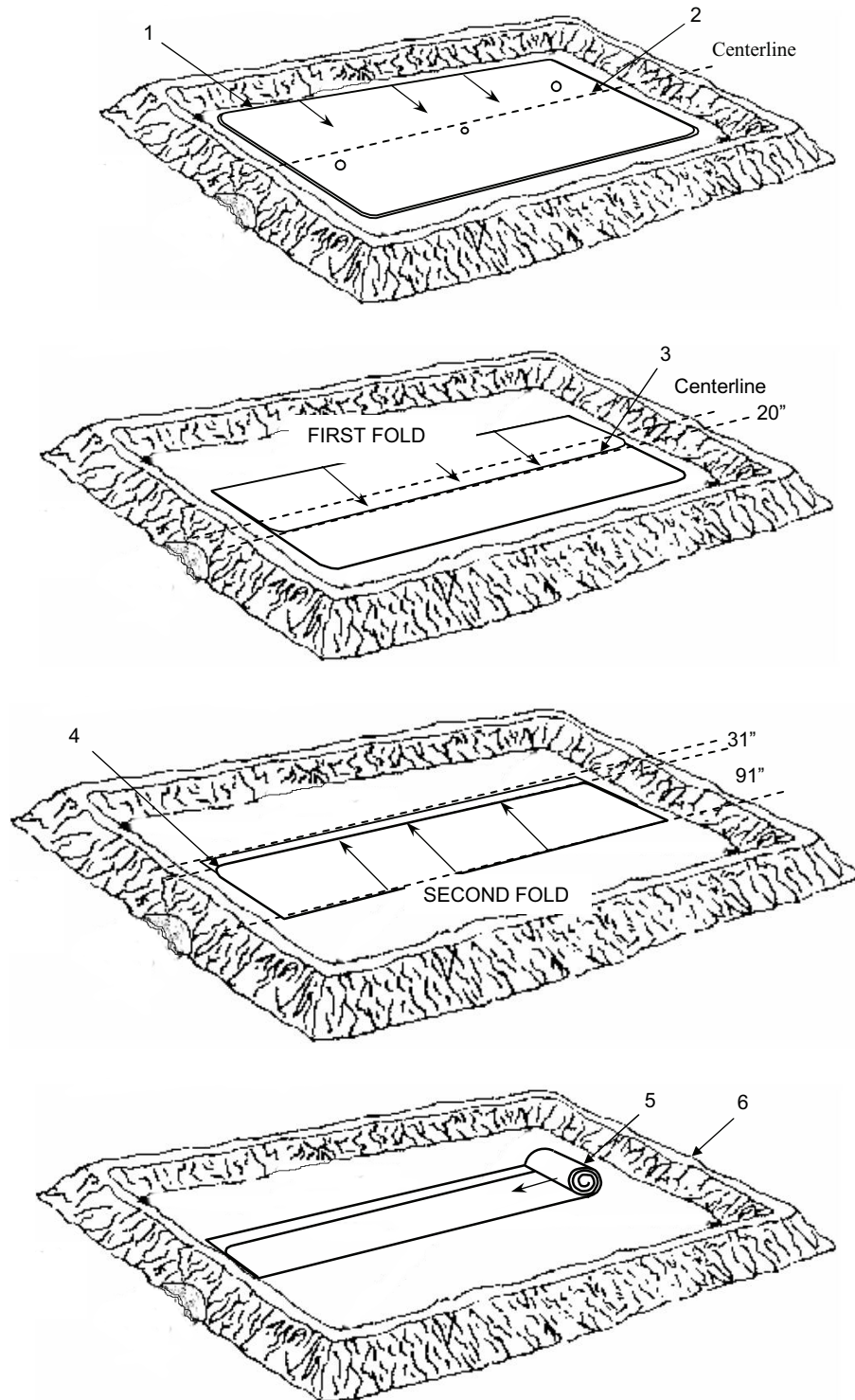

Figure 13. Tank Envelope Folding Procedures

END OF TASK

END OF WORK PACKAGE

OPERATOR INSTRUCTIONS
OPERATION UNDER UNUSUAL CONDITIONS AND EMERGENCY REPAIR PROCEDURES

INITIAL SETUP:**Materials/parts**

Rags, wiping (WP 0067, Item 4)
Detergent, general purpose (WP 0067, Item 2)

References

FM 3-11.4/5
FM 3-3
FM 3-4

Personnel Required

Water Treatment Specialist 92W

OPERATION IN EXTREME HEAT

Observe following precautions when operating Tank Envelope in extreme heat:

CAUTION

Avoid unnecessary handling of Tank Envelope at temperatures above 160°F (71°C). Separation of the coating material is possible in extremely high temperatures, causing damage.

1. Protect Tank Envelope from extreme heat by covering with tarp, setting up in a shaded area, or by constructing a sun block.
2. Ventilate area around Tank Envelope. Air should circulate freely around Tank Envelope.

END OF TASK**OPERATION IN EXTREME COLD****WARNING**

Wind may blow snow under one side of Tank Envelope, which may cause Tank Envelope to roll over causing injury to personnel.

CAUTION

If Tank Envelope is used in temperatures below freezing (32°F/0°C), caution must be used to prevent water in Tank Envelope or in contact with fluid discharge fittings from freezing. If water freezes, damage may occur to Tank Envelope and/or fittings.

Avoid unnecessary folding, unfolding, or rolling of Tank Envelope in freezing temperatures. Cracks can develop in Tank Envelope fabric, causing damage.

1. Do not allow ice to accumulate on Tank Envelope or Filler/Discharge Assemblies.
2. Keep snow and ice clear of Vent Fitting Assembly.

END OF TASK

OPERATION IN SALT WATER AREAS**CAUTION**

Salt water causes corrosion. Thoroughly clean Tank Assembly with clean, fresh water to avoid damage to equipment.

1. Use fresh, clean water to remove salt deposits from fittings.
2. Examine fittings for corrosion.
3. Report corrosion to immediate supervisor.

END OF TASK**OPERATION IN SANDY OR DUSTY AREAS**

1. Keep Dust Caps in place until fittings and couplings are ready to be used.
2. Carefully inspect coupling gaskets and remove dust, dirt, and sand from gaskets before connecting couplings.
3. Wind may blow dust or sand under one side of Tank Envelope, which may cause Tank Envelope to roll over.

END OF TASK**OPERATION IN WINDY CONDITIONS**

1. If only partially filled, Tank Envelope could roll over in windy conditions.

CAUTION

To avoid damage to equipment, do not attach restraining straps or ropes to Tank Envelope handles.

2. Secure Tank Envelope with suitable restraining straps or ropes (Figure 1) if high winds are expected.
3. Pass restraining straps or ropes under and over Tank Envelope and fasten securely to stakes in ground.

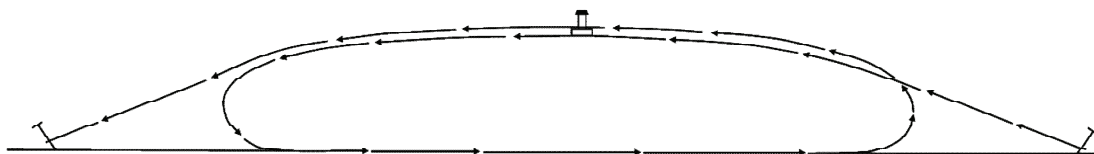

Figure 1. Tank Envelope Restraining Straps.

END OF TASK

INTERIM CHEMICAL, BIOLOGICAL, RADIOLOGICAL, AND NUCLEAR (CBRN) DECONTAMINATION PROCEDURES**WARNING**

If equipment has been exposed to chemical, biological, radiological, or nuclear warfare, equipment shall be handled with extreme caution and decontaminated in accordance with FM 3-11.5, Multiservice Tactics, Techniques, and Procedures for Chemical, Biological, Radiological, and Nuclear (CBRN) Decontamination. Unprotected personnel can experience can be injured or killed if residual toxic agents or radioactive materials are present. If equipment is exposed to chemical, biological, radiological, or nuclear agents, personnel must wear protective mask, hood, protective over garments, chemical gloves, and chemical boots in accordance with MOPP level prescribed by Officer In Charge (OIC) or Non-Commissioned Officer In Charge (NCOIC). Mission Oriented Protective Posture (MOPP) analysis and levels are described in detail in FM 3-11.4, Multiservice Tactics, Techniques, and Procedures for Nuclear, Biological, and Chemical (NBC) Protection. Personnel should contact a unit that has capability for freshwater wash down. Unit can also assist in evacuation of soldiers who have been exposed and provide space and shelter for exchanging MOPP suits.

NOTE

For detailed decontamination procedures, refer to FM 3-3, Chemical and Biological Contamination Avoidance, FM 3-4, NBC Protection, and FM 3-11.5, Multiservice Tactics, Techniques, and Procedures for Chemical, Biological, Radiological, and Nuclear (CBRN) Decontamination.

GENERAL

The following emergency procedures can be performed until field CBRN decontamination facilities are available.

CBRN EMERGENCY PROCEDURES**WARNING**

If CBRN attack is known or suspected, don mask immediately and continue mission. Mask should not be removed until instructed to do so.

1. Nuclear/Radiological decontamination – Brush fallout from skin, clothing, and equipment with available brushes, rags, or tree branches. Wash skin and undergo radiation check as soon as tactical situation permits.
2. Biological decontamination – Remain masked and continue mission until instructed to unmask.

WARNING

Do not use decontamination spray on personnel. It could cause personal injury.

3. Chemical detection and decontamination –
 - a. Use M8 paper from M256 chemical agent detector kit or M9 paper to determine if liquid agent is present on surface of equipment.

CBRN EMERGENCY PROCEDURES – CONTINUED

- b. If M8 or M9 paper indicates liquid chemical agent is present, rinse exposed portion of Tank Envelope with liberal amount of water. When tactical situation permits, wash Tank Envelope with soapy water and rinse.
- c. If exposure to liquid agent is known or suspected, clean all exposed skin, clothing, and personal gear in that order using M258A1 kit. Use buddy system. Wash exposed skin and thoroughly decontaminate as soon as tactical situation permits. Decontamination procedures take time based on tactical situation.

END OF TASK

EMERGENCY REPAIR PROCEDURES

General

Emergency repair is performed when cuts or punctures occur in Tank Envelope while in use. Emergency Repair Kit is stored in partition on inside wall of Tank Envelope shipping container. Cuts or tears in Tank Envelope smaller than 6.5 in. (16.51 cm) are repaired with Mechanical Patches. Small punctures are repaired using Wood Plugs. Damage larger than 6.5 in. (16.51 cm) requires replacement of Tank Envelope.

Emergency Repairs with Wood Plugs

In emergencies, as an immediate temporary measure, Wood Plugs can be used for sealing small holes or punctures. Size of hole or tear will determine size of Wood Plug to be used.

1. Select size of Wood Plug needed to seal Tank Envelope puncture:
 - For punctures up to approximately 0.5-in. (1.27 cm) in size, use 5/8-in. (1.59-cm) Wood Plug.
 - For punctures up to approximately 1-in. (2.54 cm) in size, use 1.5-in. (3.81-cm) Wood Plug.
 - For punctures up to approximately 1.5-in. (3.81 cm) in size, use 2-in. (5.08-cm) Wood Plug.



Figure 2. Wood Plug Installation.

2. Wet Wood Plug and insert in Tank Envelope puncture.
3. Twist Wood Plug clockwise until leak is either stopped.

EMERGENCY REPAIR PROCEDURES – CONTINUED**NOTE**

Follow-up regular inspection should be made of Wood Plugs, as possible tightening may be necessary if leak resumes.

4. Use Mechanical Patch if leak is not stopped.

Emergency Repairs with Mechanical Patches

Small slits, tears, or cuts, not to exceed 6.5 in. (16.51 cm) in length, may be repaired with Mechanical Patches.

Size of damaged area (opening) needing repair will govern size of Mechanical Patch needed. It may be necessary to increase size of fabric tear in order to be able to insert bottom plate Mechanical Patch through tear.

1. Select Mechanical Patch that is at least 1 in. (2.54 cm) larger than tear:
 - a. For holes (tears) less than 2 in. (5.08 cm) in length, use 3-in. (7.62-cm) Mechanical Patch.
 - b. For holes (tears) 2 to 4 in. (5.08 to 10.16 cm) in length, use 5-in. (12.7-cm) Mechanical Patch.
 - c. For holes (tears) 4 to 6.5 in. (10.16 to 16.51 cm) in length, use 7.5-in. (19-cm) Mechanical Patch.

CAUTION

Use extreme care when enlarging a tear. Tension in fabric may cause fabric to tear further.

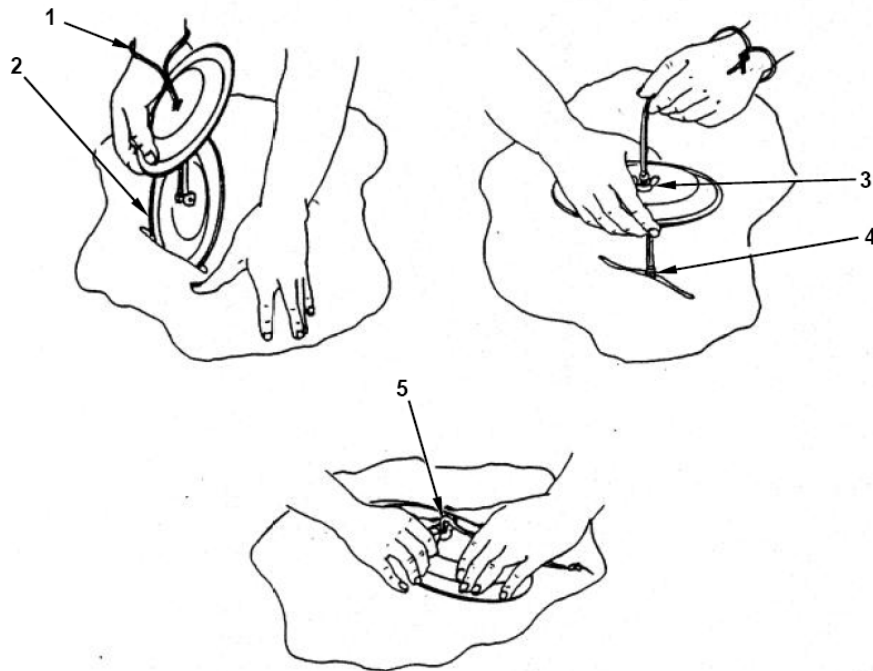

Figure 3. Installation of Mechanical Patches.

EMERGENCY REPAIR PROCEDURES – CONTINUED

2. Loop cord (Figure 3, Item 1) around wrist to prevent loss of Mechanical Patch (Figure 3, Item 2) into Tank Envelope.
3. Slip bottom plate of Mechanical Patch (Figure 3, Item 2) through hole or tear and rotate it until it is centered and its length runs with tear.
4. Pull bottom plate (Figure 3, Item 2) up against fabric and slide top plate (Figure 3, Item 3) and Wing Nut (Figure 3, Item 5) down cord and onto threaded stud (Figure 3, Item 4) of bottom plate (Figure 3, Item 2).

CAUTION

Do not over-tighten Wing Nut. Stud threads may strip or cause damage to Tank Envelope fabric.

5. With plates (Figure 3, Item 2) aligned, tighten Wing Nut (Figure 2, Item 5) clamping Tank Envelope wall between two plates (Figure 3, Item 2). Tighten Wing Nut (Figure 3, Item 5) enough to stop leak.

END OF TASK**END OF WORK PACKAGE**

CHAPTER 3

**OPERATOR TROUBLESHOOTING PROCEDURES
FOR
TANK, FABRIC, COLLAPSIBLE, WATER STORAGE,
50,000 GALLON**

**OPERATOR MAINTENANCE
TROUBLESHOOTING INDEX**

MALFUNCTION/SYMPTOM

TROUBLESHOOTING PROCEDURE

GENERAL

- 1. Operational Checkout WP 0008
- 2. Tank Assembly Leakage WP 0009
- 3. Vent Fitting Assembly WP 0010
- 4. Filler/Discharge Assembly WP 0011
- 5. Drain Fitting Assembly WP 0012
- 6. Drain Hose Assembly WP 0013
- 7. Drain Ball Valve Assembly WP 0014
- 8. Filler/Discharge Ball Valve Assembly WP 0015
- 9. Filler/Discharge Hose Assembly WP 0016
- 10. Emergency Repair Kit WP 0017

END OF TASK

END OF WORK PACKAGE

**OPERATOR MAINTENANCE
OPERATIONAL CHECKOUT**

INITIAL SETUP:**Personnel Required**

Water Treatment Specialist 92W

References

WP 0005

WP 0006

INTRODUCTION

When required, this procedure is used to ensure repair of individual parts and components of Tank Assembly. Once completed, return to associated troubleshooting work package.

WATER TANK ASSEMBLY OPERATIONAL CHECKOUT**STEP**

1. Repair parts or replacement components that were removed from Tank Assembly are installed as applicable.
2. Place Tank Assembly into operation (WP 0005 thru WP 0006).
3. Ensure part or component is operating correctly.
4. Inspect part or component that has been repaired, replaced, or determined to be operating improperly or leaking.

CONDITION/INDICATION

Tank Assembly component or part still does not operate correctly or still leaks.

CORRECTIVE ACTION

1. Shut down operation (WP 0005).
2. If not repaired, repeat repair steps or continue troubleshooting.

END OF WORK PACKAGE

**OPERATOR MAINTENANCE
TANK ASSEMBLY LEAKAGE
TROUBLESHOOTING PROCEDURES**

INITIAL SETUP:**Personnel Required**

Water Treatment Specialist 92W

Equipment Condition

Bag unfolded on smooth surface

References

WP 0006

TROUBLESHOOTING PROCEDURES**TANK ASSEMBLY LEAKAGE****SYMPTOM**

Tank Envelope leaks.

MALFUNCTION

Tank Envelope has cuts, tears, punctures, or damaged seams.

CORRECTIVE ACTION

1. Perform emergency repairs using Wood Plugs or Mechanical Patches (WP 0006).
2. If leaks continue, notify Field Maintenance.

END OF WORK PACKAGE

**OPERATOR MAINTENANCE
VENT FITTING ASSEMBLY
TROUBLESHOOTING PROCEDURES**

INITIAL SETUP:**Personnel Required**

Water Treatment Specialist 92W

Equipment Condition

Bag unfolded on smooth surface

References

WP 0020

TROUBLESHOOTING PROCEDURES**VENT FITTING ASSEMBLY****CAUTION**

To prevent possible flooding, drain Tank Envelope partially before attempting to inspect or replace gaskets or O-rings.

SYMPTOM

Vent Fitting Assembly leaks.

MALFUNCTION

Gasket between Coupling Half and Flanged Adapter.

CORRECTIVE ACTION

Replace Gasket (WP 0020).

MALFUNCTION

Vent Fitting Assembly continues to leak.

CORRECTIVE ACTION

Notify Field Maintenance.

MALFUNCTION

Coupling Half leaks.

CORRECTIVE ACTION

Notify Field Maintenance.

END OF WORK PACKAGE

**OPERATOR MAINTENANCE
FILLER/DISCHARGE ASSEMBLY
TROUBLESHOOTING PROCEDURES**

INITIAL SETUP:**Personnel Required**

Water Treatment Specialist 92W

References

WP 0021

TROUBLESHOOTING PROCEDURES**FILLER/DISCHARGE ASSEMBLY****SYMPTOM**

Filler/Discharge Assembly leaks.

MALFUNCTION

Gasket between Filler/Discharge Elbow and Flanged Adapter leaks.

CORRECTIVE ACTION

Replace Gasket (WP 0021).

MALFUNCTION

Filler/Discharge fittings are loose or damaged.

CORRECTIVE ACTION

Notify Field Maintenance.

MALFUNCTION

Dust Cap improperly installed or worn.

CORRECTIVE ACTION

Reinstall Dust Cap if improperly installed, or replace if worn (WP 0021).

END OF WORK PACKAGE

**OPERATOR MAINTENANCE
DRAIN FITTING ASSEMBLY
TROUBLESHOOTING PROCEDURES**

INITIAL SETUP:**Personnel Required**

Water Treatment Specialist 92W

TROUBLESHOOTING PROCEDURES**DRAIN FITTING ASSEMBLY****SYMPTOM**

Drain Fitting Assembly leaks between Drain Fitting Assembly and Tank Envelope fitting.

MALFUNCTION

Washers or screws are missing or loose.

CORRECTIVE ACTION

Notify Field Maintenance.

MALFUNCTION

O-ring between Blind Flange Cover and Tank Envelope fitting is nicked, broken or compressed.

CORRECTIVE ACTION

If damaged, notify Field Maintenance.

MALFUNCTION

Blind Flange Cover is damaged or cracked.

CORRECTIVE ACTION

Notify Field Maintenance.

END OF WORK PACKAGE

**OPERATOR MAINTENANCE
DRAIN HOSE ASSEMBLY
TROUBLESHOOTING PROCEDURES**

INITIAL SETUP:**Personnel Required**

Water Treatment Specialist 92W

Equipment Condition

Bag unfolded on smooth surface

TROUBLESHOOTING PROCEDURES**DRAIN HOSE ASSEMBLY****CAUTION**

To prevent possible flooding, drain Tank Envelope partially before attempting to inspect or replace Gasket.

SYMPTOM

Drain Hose Assembly leaks.

MALFUNCTION

Drain Hose Assembly leaks or is broken.

CORRECTIVE ACTION

Notify Field Maintenance.

END OF WORK PACKAGE

**OPERATOR MAINTENANCE
DRAIN BALL VALVE ASSEMBLY
TROUBLESHOOTING PROCEDURES**

INITIAL SETUP:**Personnel Required**

Water Treatment Specialist 92W

TROUBLESHOOTING PROCEDURES**DRAIN BALL VALVE****SYMPTOM**

Drain Valve leaks.

MALFUNCTION

Drain Valve is not closed completely.

CORRECTIVE ACTION

Tightly close Drain Valve.

MALFUNCTION

Drain Valve is damaged or worn.

CORRECTIVE ACTION

Notify Field Maintenance.

MALFUNCTION

Drain Valve is not properly aligned.

CORRECTIVE ACTION

Align Drain Valve. If still leaking, notify Field Maintenance.

END OF WORK PACKAGE

**OPERATOR MAINTENANCE
FILLER/DISCHARGE BALL VALVE ASSEMBLY
TROUBLESHOOTING PROCEDURES**

INITIAL SETUP:**Personnel Required**

Water Treatment Specialist 92W

References

WP 0023

TROUBLESHOOTING PROCEDURES**FILLER/DISCHARGE BALL VALVE ASSEMBLY****SYMPTOM**

Filler/Discharge Valve leaks.

MALFUNCTION

Filler/Discharge Valve is not closed completely.

CORRECTIVE ACTION

Tightly close Filler/Discharge Valve.

MALFUNCTION

Gaskets are damaged or missing.

CORRECTIVE ACTION

Replace Gasket (WP 0023).

MALFUNCTION

Filler/Discharge Valve is damaged or worn.

CORRECTIVE ACTION

Notify Field Maintenance.

MALFUNCTION

Filler/Discharge Valve is improperly aligned.

CORRECTIVE ACTION

Align Filler/Discharge Valve. If still leaking, notify Field Maintenance.

FILLER/DISCHARGE BALL VALVE ASSEMBLY – CONTINUED

MALFUNCTION

Filler/Discharge Couplings are damaged or worn.

CORRECTIVE ACTION

Notify Field Maintenance.

END OF WORK PACKAGE

**OPERATOR MAINTENANCE
FILLER/DISCHARGE HOSE ASSEMBLY
TROUBLESHOOTING PROCEDURES**

INITIAL SETUP:**Personnel Required**

Water Treatment Specialist 92W

ReferencesWP 0021
WP 0023

TROUBLESHOOTING PROCEDURES**FILLER/DISCHARGE HOSE ASSEMBLY****SYMPTOM**

Filler/Discharge Hose Assembly leaks.

MALFUNCTION

Filler/Discharge Hose is torn or broken.

CORRECTIVE ACTION

Notify Field Maintenance.

MALFUNCTION

Gasket is damaged or worn.

CORRECTIVE ACTION

Replace Gasket between hose and ball valve (WP 0023) or gasket between hose and Filler/Discharge Elbow (WP 0021).

MALFUNCTION

Coupling is dirty, damaged, or worn.

CORRECTIVE ACTION

1. Remove dirt or debris from inside Coupling.
2. Notify Field Maintenance.

END OF WORK PACKAGE

**OPERATOR MAINTENANCE
EMERGENCY REPAIR KIT
TROUBLESHOOTING PROCEDURES**

INITIAL SETUP:**Personnel Required**

Water Treatment Specialist 92W

Equipment Condition

Bag unfolded on smooth surface

References

WP 0059

TROUBLESHOOTING PROCEDURES**EMERGENCY REPAIR ITEMS****SYMPTOM**

Component of Emergency Repair Kit missing.

MALFUNCTION

Emergency Repair Kit items are missing.

CORRECTIVE ACTION

Replace missing items in Emergency Repair Kit (WP 0059).

END OF WORK PACKAGE

CHAPTER 4

**OPERATOR MAINTENANCE INSTRUCTIONS
FOR
TANK, FABRIC, COLLAPSIBLE, WATER STORAGE,
50,000 GALLON**

OPERATOR MAINTENANCE PREVENTIVE MAINTENANCE CHECKS AND SERVICES (PMCS) INTRODUCTION

GENERAL

Preventive Maintenance Checks and Services (PMCS) are performed to keep the Tank Assembly in operating condition. Checks are used to find, correct, or report problems. Operators should perform PMCS as shown in the PMCS table. Using the PMCS table, preventive maintenance checks and services are performed every day the equipment is operated. Pay attention to WARNING and CAUTION statements. A WARNING indicates that someone could be injured or killed. A CAUTION indicates the possibility of equipment damage.

Before operating the equipment, **BEFORE** PMCS should be conducted.

Perform **DURING** PMCS during equipment operation.

AFTER PMCS should be performed upon completion of equipment operation.

Use troubleshooting and/or maintenance procedures to correct problems found when performing PMCS.

The right-hand column of the PMCS table lists conditions that classify the equipment as *not fully mission capable*. Report items as *not-fixed* on DA Form 2404 or DA Form 5988-E for Field Maintenance. For further information on how to use this form, see DA PAM 750-8.

If tools are required to perform PMCS and not listed in WP 0064 Table 2, notify Field Maintenance.

LEAKAGE DEFINITIONS

It is important to understand how fluid leakage affects the status of the Tank Assembly. Following are definitions of the leakage classes the operator needs to become familiar with in order to be able to determine the condition of the leak. Remember, when in doubt, always consult your supervisor.

Leakage Classifications for Operator PMCS:

CLASS I - Seepage of water (as indicated by wetness or discoloration) not great enough to form drops.

CLASS II - Leakage of water great enough to form drops but not enough to cause drops to drip from item being inspected.

CLASS III - Leakage of water great enough to form drops that fall from the item being inspected.

INSPECTION

Look for signs of a problem or trouble. You can feel, smell, hear or see many problems. Be alert when using the equipment.

Inspect to ensure Items are in good condition. Are they correctly assembled, properly lubricated, stowed, secured, excessively worn, leaking, or corroded? Correct any problems found or notify Field Maintenance.

The following are common items to check throughout the equipment:

1. Bolts, clamps, nuts and screws: Continually check for looseness. Look for chipped paint, bare metal, rust, or corrosion around bolt and screw heads and nuts. Tighten these when loose. If tools are not available, contact Field Maintenance.
2. Hoses and fluid lines: Look for wear, damage, and leaks. Ensure that clamps and fittings are tight. Wet spots indicate leakage. A stain near a fitting or connector can also indicate leakage. If a leak is discovered, notify Field Maintenance.

CORROSION PREVENTION AND CONTROL (CPC)

Corrosion Prevention and Control (CPC) of Army materiel is a continuing concern. It is important that any corrosion problems with this item be reported so corrections and improvements can be made to prevent problems in future items.

Corrosion is typically associated with rusting of metals or galvanic corrosion, which produces a white powder. Corrosion also includes deterioration of other materials, such as rubber and plastic. Unusual cracking, softening, swelling, or breaking of the materials may indicate corrosion problems. If a corrosion problem is identified, it can be reported using SF 368 Product Quality Deficiency Report. Use of key words, such as "corrosion," "rust," "deterioration," or "cracking," will ensure that the information is identified as a CPC problem. The form should be submitted to the address specified in DA PAM 750-8.

ARMY OIL ANALYSIS PROGRAM (AOAP)

This Tank Assembly is not enrolled in the Army Oil Analysis Program.

END OF TASK**END OF WORK PACKAGE**

**OPERATOR MAINTENANCE
PREVENTIVE MAINTENANCE CHECKS AND SERVICES (PMCS) AND LUBRICATION
PROCEDURES**

INITIAL SETUP:

Personnel Required

Water Treatment Specialist 92W

PMCS PROCEDURES

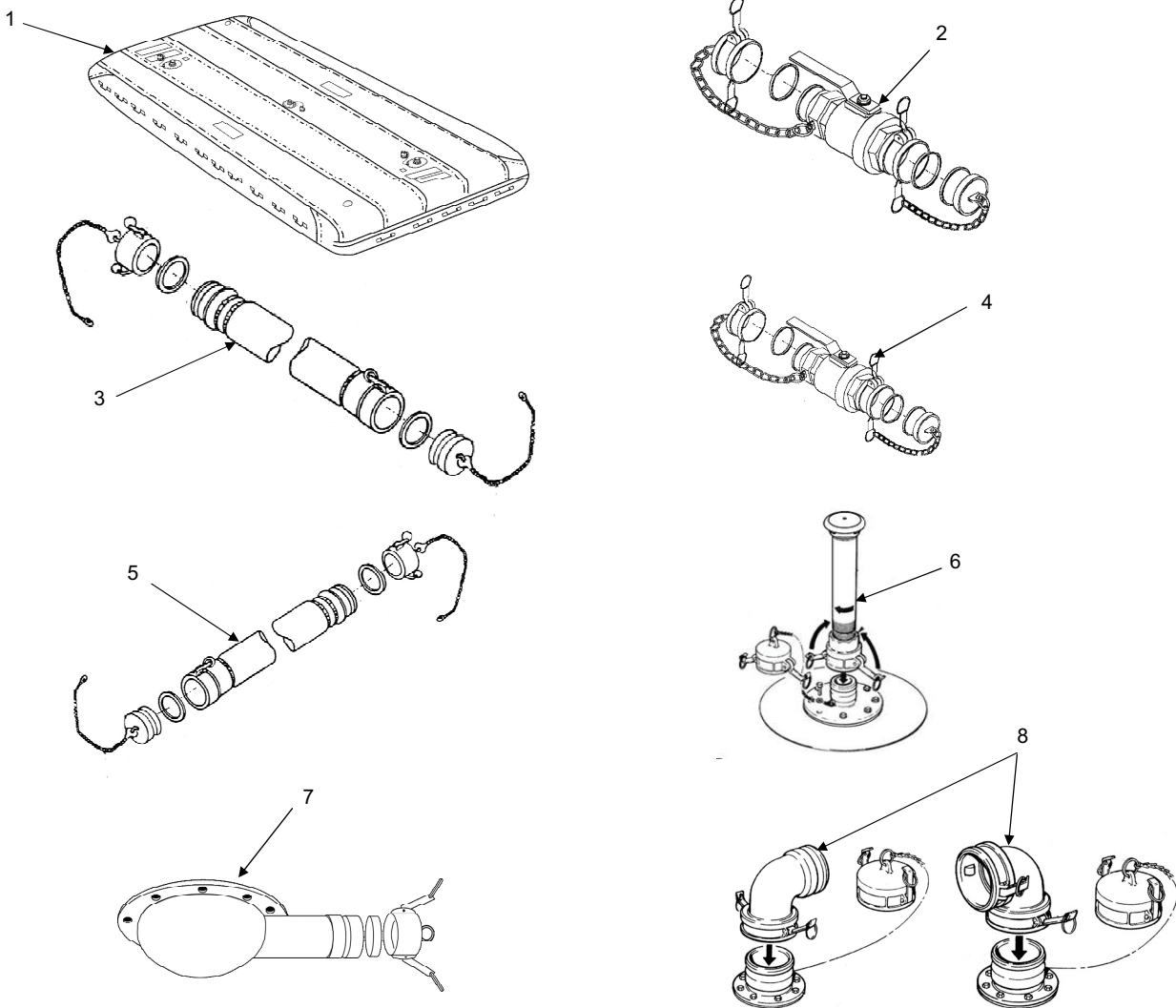

PMCS PROCEDURES – CONTINUED

Table 1. Preventive Maintenance Checks and Services (PMCS).

ITEM NO.	INTERVAL	ITEM TO BE CHECKED OR SERVICED	PROCEDURE	EQUIPMENT NOT READY/ AVAILABLE IF:
1	Before	Installation Area	Inspect installation area for sticks and other sharp objects that might cause punctures and leaks.	Sharp objects are present.
2	Before	Tank Envelope (1)	Inspect for tears or punctures. NOTE Air pockets trapped between tank envelope and interior chafing patches sometimes occur during manufacturing. This does not affect the functionality of the tank.	Tank Envelope has tears or punctures that cannot be repaired.
3	Before	Filler/Discharge Ball Valve Assembly (2)	1. Check for bent or broken hardware. 2. Check gasket and cam-lever arms for damage. 3. Check for missing or damaged Dust Caps and plugs.	Handle, gasket, or cam-lever arms are damaged or missing.
4	Before	Filler/Discharge Hose Assembly (3)	1. Check Filler/Discharge Hose Assembly for cuts and tears. 2. Check fittings for distortion and damage, or missing gaskets, Dust Caps and plugs.	Filler/Discharge Hose Assembly is damaged. Gaskets, Dust Caps or plugs are damaged or missing.
5	Before	Drain Ball Valve Assembly (4)	1. Check for bent or broken handle. 2. Check for missing or damaged Dust Caps and plugs.	Handle is damaged or missing. Dust caps or plugs damaged or missing.
6	Before	Drain Hose Assembly (5)	1. Check Drain Hose for cuts and tears.	Drain Hose assembly is damaged.

PMCS PROCEDURES – CONTINUED

Table 1. Preventive Maintenance Checks and Services (PMCS) – Continued.

ITEM NO.	INTERVAL	ITEM TO BE CHECKED OR SERVICED	PROCEDURE	EQUIPMENT NOT READY/ AVAILABLE IF:
7	Before	Vent Fitting Assembly (6)	2. Check fittings for distortion or damage. 1. Check Vent Cap, gaskets, and cam-lever arms for evidence of leakage, damage, or missing parts. 2. Check Vent Cap for cleanliness and freedom of operation.	Vent Cap is damaged or missing. Vent Cap, gasket, flat rubber gasket, or cam-lever arms are damaged or missing.
8	Before	Drain Fitting Assemblies (7)	Check Drain Bowl Fitting, Drain Hose, or Drain Valve for damaged or missing parts.	Drain Bowl Fitting, Drain Hose, or Drain Valve are missing, not properly connected, or damaged. Class III leak found.
9	Before	Filler/Discharge Assembly (8)	Check cam-lever arms and elbow for damage.	Cam-lever arms damaged or missing. Filler/Discharge Elbow is cracked or worn.
10	During	Installation Area	Inspect installation area for sticks and other sharp objects.	Sharp objects are present.
11	During	Tank Envelope (1)	Inspect for tears, punctures, or leaks.	Tank Envelope has tears, punctures, or leaks that cannot be repaired.
12	During	Filler/Discharge Ball Valve Assembly (2)	1. Check for bent or broken hardware and leaks. 2. Check gasket and cam-lever arms for damage.	Handle, gasket, or cam-lever arms are damaged, missing, or leaking.
13	During	Filler/Discharge Hose Assembly (3)	1. Check Filler/Discharge Hose for leaks, cuts, and tears. 2. Check fittings for distortion or damage.	Filler/Discharge Hose leaks or is damaged.

PMCS PROCEDURES – CONTINUED

Table 1. Preventive Maintenance Checks and Services (PMCS) – Continued.

ITEM NO.	INTERVAL	ITEM TO BE CHECKED OR SERVICED	PROCEDURE	EQUIPMENT NOT READY/ AVAILABLE IF:
14	During	Drain Ball Valve Assembly (4)	Check for bent or broken handle, and leakage.	
15	During	Drain Hose Assembly (5)	<ol style="list-style-type: none"> 1. Check Drain Hose for leaks, cuts, and tears. 2. Check fittings for distortion or damage. 	Drain Hose Assembly leaks or is damaged.
16	During	Vent Fitting Assembly (6)	<ol style="list-style-type: none"> 1. Check Vent Cap, gaskets, and cam-lever arms for evidence of leakage, damage, or missing parts. 2. Check Vent Cap for cleanliness and freedom of operation. 3. Check for damaged or missing gaskets. 	Vent Cap is damaged or missing. Gaskets or cam-lever arms are damaged or missing.
17	During	Drain Fitting Assemblies (7)	<ol style="list-style-type: none"> 1. Check immediate area for evidence of leakage. 2. Check Drain Bowl Fitting, Drain Hose, or Drain Valve for damaged or missing parts. 	Drain plug, drain hose, or drain ball valve missing, not properly connected, or damaged.
18	During	Filler/Discharge Assembly (8)	Check cam-lever arm and Filler/Discharge Elbows for damage or leaks.	Cam-lever arms damaged or missing. Filler/Discharge Elbow is cracked. Filler/Discharge Elbow sealing surface is badly dented.

PMCS PROCEDURES – CONTINUED

Table 1. Preventive Maintenance Checks and Services (PMCS) – Continued.

ITEM NO.	INTERVAL	ITEM TO BE CHECKED OR SERVICED	PROCEDURE	EQUIPMENT NOT READY/ AVAILABLE IF:
19	After	Tank Envelope (1)	Inspect for tears and punctures. NOTE Air pockets trapped between tank envelope and interior chafing patches sometimes occur during manufacturing. This does not affect the functionality of the tank	Tank Envelope has tears or punctures that cannot be repaired.
20	After	Filler/Discharge Ball Valve Assembly (2)	1. Check for bent or broken hardware. 2. Check gaskets and cam lever arms for damage. 3. Check for missing or damaged Dust Caps and plugs.	Handle, gasket, or cam-lever arms are damaged or missing. Dust caps or plugs missing or damaged.
21	After	Filler/Discharge Hose Assembly (3)	1. Check Filler/Discharge Hose Assembly for cuts and tears. 2. Check fittings for distortion and damage, or missing gaskets, Dust Caps and plugs.	Filler/Discharge Hose Assembly is damaged. Gaskets, Dust Caps and plugs are damaged or missing.
22	After	Drain Ball Valve Assembly (4)	1. Check for bent or broken handle. 2. Check for missing or damaged Dust Caps and plugs.	Handle is damaged or missing. Dust caps or plugs are missing or damaged.
23	After	Drain Hose Assembly (5)	1. Check Drain Hose for cuts and tears. 2. Check fittings for distortion and damage.	Drain Hose Assembly is damaged.

PMCS PROCEDURES – CONTINUED

Table 1. Preventive Maintenance Checks and Services (PMCS) – Continued.

ITEM NO.	INTERVAL	ITEM TO BE CHECKED OR SERVICED	PROCEDURE	EQUIPMENT NOT READY/ AVAILABLE IF:
24	After	Vent Fitting Assembly (6)	1. Check Vent Cap, gaskets, and cam-lever arms for damage or missing parts.	Vent Cap is damaged or missing. Gaskets, or cam-lever arms are damaged or missing.
			2. Check Vent Cap for cleanliness and freedom of operation.	
			3. Check for damaged or missing gaskets.	
25	After	Drain Fitting Assemblies (7)	Check Drain Bowl Fitting, Drain Hose, or Drain Valve for damaged or missing parts.	Drain plug, drain hose, or drain ball valve are missing, not properly connected, or damaged.
26	After	Filler/Discharge Assembly (8)	Check cam-lever arm and Filler/Discharge Elbow body for damage.	Cam-lever arms damaged or missing. Filler/Discharge Elbow cracked or worn.
27	Semiannual	Tank (1) Interior	Check coating for cracking.	Coating is cracked, allowing leaks.

LUBRICATION INSTRUCTIONS

Lubrication instructions do not apply to this equipment.

END OF WORK PACKAGE

**OPERATOR MAINTENANCE
VENT FITTING ASSEMBLY
REPAIR**

INITIAL SETUP:**Materials/Parts**

Gasket (2) (WP 0068, Item 1)

Equipment Condition

Tank empty, on level surface

Personnel Required

Water Treatment Specialist 92W

NOTE

Operator repair of Vent Fitting Assembly is limited to replacement of defective gaskets.

REMOVAL OF COUPLING AND DUST CAP GASKETS

1. Disconnect Coupling Half (Figure 1, Item 1) from Flanged Adapter (Figure 1, Item 2) by pulling outward on cam-lever arms (Figure 1, Item 3).
2. Lift Coupling Half (Figure 1, Item 1) from Flanged Adapter (Figure 1, Item 2).
3. Remove Coupling Half Gasket (Figure 1, Item 4). Discard Gasket.
4. Remove Gasket (Figure 1, Item 5) from inside Dust Cap (Figure 1, Item 6). Discard Gasket.

NOTE

Vent Pipe and Vent Cap removed for clarity.

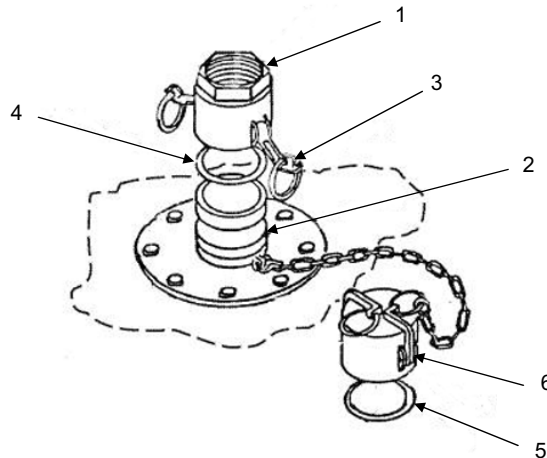

Figure 1. Vent Fitting Assembly.

END OF TASK

INSTALLATION OF COUPLING AND DUST CAP GASKETS

1. Seat new Gasket (Figure 1, Item 4) into Coupling Half (Figure 1, Item 1).
2. With cam-lever arms (Figure 1, Item 3) in outward position, install Coupling Half (Figure 1, Item 1) to Flanged Adapter (Figure 1, Item 2).
3. Push cam-lever arms (Figure 1, Item 3) inward until they lock in place.
4. Seat new Gasket (Figure 1, Item 5) into Dust Cap (Figure 1, Item 6).

END OF TASK**END OF WORK PACKAGE**

**OPERATOR MAINTENANCE
FILLER/DISCHARGE ASSEMBLY
REPAIR**

INITIAL SETUP:**Materials/Parts**

Gasket (2) (WP 0068, Item 2)

Personnel Required

Water Treatment Specialist 92W

NOTE

Operator repair of Filler/Discharge Assembly is limited to replacement of defective gaskets.

REMOVAL OF FILLER/DISCHARGE ASSEMBLY ELBOW AND DUST CAP GASKETS

1. Remove Filler/Discharge Elbow (Figure 1, Item 1) or Dust Cap (Figure 1, Item 2) by pulling outward on cam-lever arms (Figure 1, Item 3), and lifting Filler/Discharge Elbow (Figure 1, Item 1) or Dust Cap (Figure 1, Item 2) from Flanged Adapter (Figure 1, Item 4).

NOTE

Filler Elbow has two Gaskets.

2. Remove Gasket (Figure 1, Item 5) from Filler/Discharge Elbow (Figure 1, Item 1) and Gasket (Figure 1, Item 6) from Dust Cap (Figure 1, Item 2). Discard Gaskets.

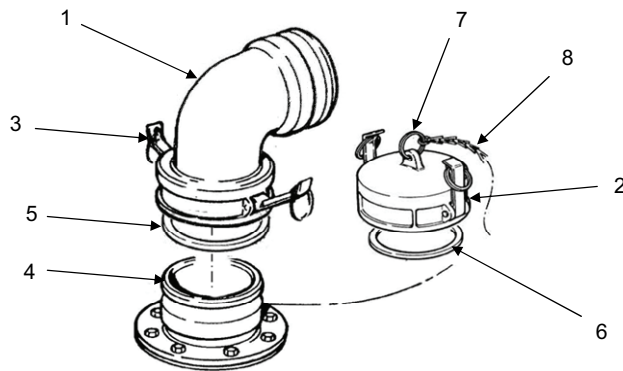

Figure 1. Filler/Discharge Assembly.

END OF TASK

INSTALLATION FILLER/DISCHARGE ASSEMBLY ELBOW AND DUST CAP GASKETS**NOTE**

Filler Elbow requires two Gaskets.

1. Place new Gasket (Figure 1, Item 5) into Filler/Discharge Elbow (Figure 1, Item 1) and new Gasket (Figure 1, Item 6) in Dust Cap (Figure 1, Item 2).
2. Install Filler/Discharge Elbow (Figure 1, Item 1) onto Flanged Adapter (Figure 1, Item 4) by pushing inward on cam-lever arms (Figure 1, Item 3) to lock Filler/Discharge Elbow (Figure 1, Item 1) into position.
3. Install Dust Cap (Figure 1, Item 2) on Filler/Discharge Elbow (Figure 1, Item 1) by pushing inward on cam-lever arms (Figure 1, Item 3) of Dust Cap (Figure 1, Item 2) to lock into position.

END OF TASK

END OF WORK PACKAGE

**OPERATOR MAINTENANCE
DRAIN BALL VALVE ASSEMBLY
REPAIR**

INITIAL SETUP:**Materials/Parts**

Gasket (2) (WP 0068, Item 1)

Personnel Required

Water Treatment Specialist 92W

NOTE

Operator repair of Drain Ball Valve Assembly is limited to replacement of defective gaskets.

REMOVAL OF DRAIN BALL VALVE GASKETS

Figure 1. Drain Ball Valve Assembly.

1. Pull cam-lever arms (Figure 1, Item 1) on Dust Cap (Figure 1, Item 2) out, away from Dust Cap (Figure 1, Item 2) body.
2. Remove Dust Cap (Figure 1, Item 2) from Male Coupling (Figure 1, Item 3).
3. Remove Gasket (Figure 1, Item 4) from Dust Cap (Figure 1, Item 2).
4. Pull cam-lever arms (Figure 1, Item 5) on Female Coupling (Figure 1, Item 6) out, away from Female Coupling (Figure 1, Item 6) body.
5. Remove Dust Plug (Figure 1, Item 7) from Female Coupling (Figure 1, Item 6).
6. Remove Gasket (Figure 1, Item 8) from Female Coupling (Figure 1, Item 6).
7. Discard Gaskets.

END OF TASK

INSTALLATION OF DRAIN BALL VALVE GASKETS

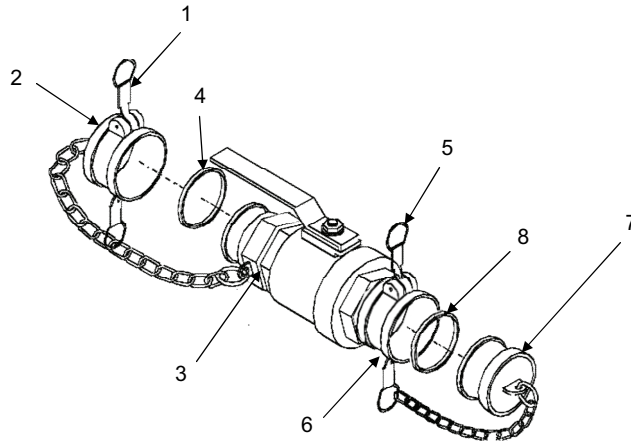
1. Install new Gasket (Figure 1, Item 8) in Female Coupling (Figure 1, Item 6).
2. Push cam-lever arms (Figure 1, Item 5) on Female Coupling (Figure 1, Item 6) outward, away from body of Female Coupling (Figure 1, Item 6).
3. Install Dust Plug (Figure 1, Item 7) in Female Coupling (Figure 1, Item 6).
4. Push cam-lever arms (Figure 1, Item 5) on Female Coupling (Figure 1, Item 6) inward toward body of Female Coupling (Figure 1, Item 6) until locked.
5. Install new Gasket (Figure 1, Item 4) in Dust Cap (Figure 1, Item 2).
6. Push cam-lever arms (Figure 1, Item 1) on Dust Cap (Figure 1, Item 2) outward, away from body of Dust Cap (Figure 1, Item 2).
7. Install Dust Cap (Figure 1, Item 2) on Male Coupling (Figure 1, Item 3).
8. Push cam-lever arms (Figure 1, Item 1) on Dust Cap (Figure 1, Item 2) inward toward body of Dust Cap (Figure 1, Item 2) until locked.

END OF TASK**END OF WORK PACKAGE**

**OPERATOR MAINTENANCE
FILLER/DISCHARGE BALL VALVE ASSEMBLY
REPAIR**

INITIAL SETUP:**Materials/Parts**

Gasket (2) (WP 0068, Item 2)

Personnel Required

Water Treatment Specialist 92W

NOTE

Operator repair of Filler/Discharge Ball Valve Assembly is limited to replacement of defective gaskets.

REMOVAL OF FILLER/DISCHARGE BALL VALVE GASKETS

Figure 1. Filler/Discharge Ball Valve Assembly.

8. Pull cam-lever arms (Figure 1, Item 1) on Dust Cap (Figure 1, Item 2) out, away from Dust Cap (Figure 1, Item 2) body.
9. Remove Dust Cap (Figure 1, Item 2) from Male Coupling (Figure 1, Item 3).
10. Remove Gasket (Figure 1, Item 4) from Dust Cap (Figure 1, Item 2).
11. Pull cam-lever arms (Figure 1, Item 5) on Female Coupling (Figure 1, Item 6) out, away from Female Coupling (Figure 1, Item 6) body.
12. Remove Dust Plug (Figure 1, Item 7) from Female Coupling (Figure 1, Item 6).
13. Remove Gasket (Figure 1, Item 8) from Female Coupling (Figure 1, Item 6).
14. Discard Gaskets.

END OF TASK

INSTALLATION OF FILLER/DISCHARGE BALL VALVE GASKETS

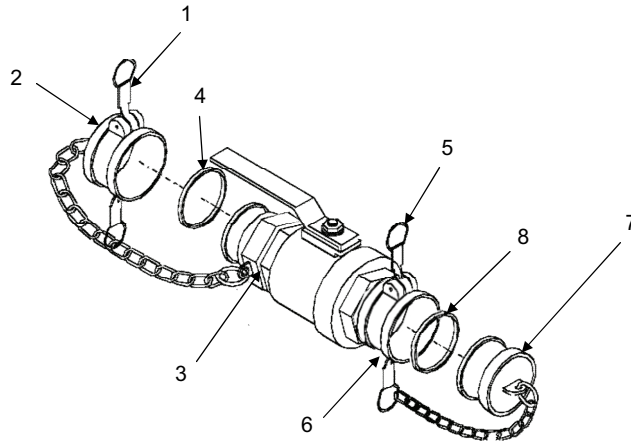
9. Install new Gasket (Figure 1, Item 8) in Female Coupling (Figure 1, Item 6).
10. Push cam-lever arms (Figure 1, Item 5) on Female Coupling (Figure 1, Item 6) outward, away from body of Female Coupling (Figure 1, Item 6).
11. Install Dust Plug (Figure 1, Item 7) in Female Coupling (Figure 1, Item 6).
12. Push cam-lever arms (Figure 1, Item 5) on Female Coupling (Figure 1, Item 6) inward toward body of Female Coupling (Figure 1, Item 6) until locked.
13. Install new Gasket (Figure 1, Item 4) in Dust Cap (Figure 1, Item 2).
14. Push cam-lever arms (Figure 1, Item 1) on Dust Cap (Figure 1, Item 2) outward, away from body of Dust Cap (Figure 1, Item 2).
15. Install Dust Cap (Figure 1, Item 2) on Male Coupling (Figure 1, Item 3).
16. Push cam-lever arms (Figure 1, Item 1) on Dust Cap (Figure 1, Item 2) inward toward body of Dust Cap (Figure 1, Item 2) until locked.

END OF TASK**END OF WORK PACKAGE**

CHAPTER 5

FIELD MAINTENANCE TROUBLESHOOTING PROCEDURES
FOR
TANK, FABRIC, COLLAPSIBLE, WATER STORAGE,
50,000 GALLON

**FIELD MAINTENANCE
TROUBLESHOOTING INDEX**

MALFUNCTION/SYMPTOM

TROUBLESHOOTING PROCEDURE

GENERAL

- 1. Tank Assembly Leakage..... WP 0025
- 2. Vent Fitting Assembly WP 0026
- 3. Filler/Discharge Assembly WP 0027
- 4. Drain Fitting Assembly WP 0028
- 5. Drain Hose Assembly WP 0029
- 6. Drain Ball Valve Assembly WP 0030
- 7. Filler/Discharge Ball Valve Assembly..... WP 0031
- 8. Filler/Discharge Hose Assembly WP 0032

END OF TASK

END OF WORK PACKAGE

**FIELD MAINTENANCE
TANK ASSEMBLY LEAKAGE
TROUBLESHOOTING PROCEDURES**

INITIAL SETUP:**Personnel Required**

Quartermaster and Chemical Equipment
Repairer 63J

References

WP 0006

TROUBLESHOOTING PROCEDURES**TANK ASSEMBLY LEAKAGE****SYMPTOM**

Tank Envelope leaks.

MALFUNCTION

Tank Envelope has cuts, tears, punctures, or damaged seams.

CORRECTIVE ACTION

1. Perform emergency repairs using Wood Plugs or Mechanical Patches (WP 0006).
2. If leak cannot be repaired, immediately notify supervisor.

END OF WORK PACKAGE

**FIELD MAINTENANCE
VENT FITTING ASSEMBLY
TROUBLESHOOTING PROCEDURES**

INITIAL SETUP:**Personnel Required**

Quartermaster and Chemical Equipment
Repairer 63J

References

WP 0038

TROUBLESHOOTING PROCEDURES**VENT FITTING ASSEMBLY****CAUTION**

To prevent possible flooding, drain Tank Envelope partially before attempting to inspect or replace gaskets or seals.

SYMPTOM

Vent Pipe leaks.

MALFUNCTION

Vent Pipe O-ring is cracked, distorted, or worn.

CORRECTIVE ACTION

Service, repair, or replace O-ring (WP 0038).

MALFUNCTION

Vent Pipe is cracked, bent, or damaged.

CORRECTIVE ACTION

Replace Vent Pipe (WP 0038).

MALFUNCTION

Gasket between Coupling Half and Flanged Adapter is damaged.

CORRECTIVE ACTION

Replace Gasket (WP 0038).

VENT FITTING ASSEMBLY – CONTINUED**MALFUNCTION**

Flanged Adapter is cracked or broken.

CORRECTIVE ACTION

Replace Flanged Adapter (WP 0038).

MALFUNCTION

Screws or Washers are loose or missing.

CORRECTIVE ACTION

Replace missing Screws and Washers (WP 0038).

END OF WORK PACKAGE

**FIELD MAINTENANCE
FILLER/DISCHARGE ASSEMBLY
TROUBLESHOOTING PROCEDURES**

INITIAL SETUP:**Personnel Required**

Quartermaster and Chemical Equipment
Repairer 63J

References

WP 0039

TROUBLESHOOTING PROCEDURES**FILLER/DISCHARGE ASSEMBLY****CAUTION**

To prevent possible flooding, drain Tank Envelope partially before attempting to inspect or replace gaskets or seals.

SYMPTOM

Filler/Discharge Assembly leaks between Compression Plate and Tank Envelope fitting.

MALFUNCTION

Washers or Screws are missing or loose.

CORRECTIVE ACTION

Replace missing washer and screws (WP 0039).

MALFUNCTION

Gasket between Compression Plate and Tank Envelope fitting is nicked, broken, or compressed.

CORRECTIVE ACTION

Replace Gasket (WP 0039).

SYMPTOM

Filler/Discharge Assembly leaks between Compression Plate and Flanged Adapter.

MALFUNCTION

Nuts, Lock Washers, Gaskets, or Screws are missing or loose.

FILLER/DISCHARGE ASSEMBLY – CONTINUED**CORRECTIVE ACTION**

Replace missing Nuts, Lock Washers, Gaskets, or Screws (WP 0039).

MALFUNCTION

Flanged Adapter Gasket is damaged or worn.

CORRECTIVE ACTION

Remove Flanged Adapter from Compression Plate and replace damaged Gasket (WP 0039).

SYMPTOM

Filler/Discharge Assembly leaks through hardware or will not assemble.

MALFUNCTION

Filler/Discharge Assembly fastening hardware is cracked, damaged, or worn.

CORRECTIVE ACTION

Replace fastening hardware as required (WP 0039).

SYMPTOM

Filler/Discharge Elbows leak.

MALFUNCTION

Filler/Discharge Elbows are cracked, dented, worn, or Gaskets are damaged or missing.

CORRECTIVE ACTION

Replace damaged Filler/Discharge Elbows and Gaskets (WP 0039).

END OF WORK PACKAGE

**FIELD MAINTENANCE
DRAIN FITTING ASSEMBLY
TROUBLESHOOTING PROCEDURES**

INITIAL SETUP:**Personnel Required**

Quartermaster and Chemical Equipment
Repairer 63J

References

WP 0040

TROUBLESHOOTING PROCEDURES**DRAIN FITTING ASSEMBLY****CAUTION**

To prevent possible flooding, drain Tank Envelope partially before attempting to inspect or replace gaskets or seals.

SYMPTOM

Drain Fitting Assembly leaks between Drain Bowl Fitting and Tank Envelope.

MALFUNCTION

Washers or Screws are loose or missing.

CORRECTIVE ACTION

Replace missing Screws or Washers (WP 0040).

MALFUNCTION

O-ring between Blind Flange Cover and Tank Envelope fitting is nicked, broken, or compressed.

CORRECTIVE ACTION

Replace O-ring (WP 0040)

CORRECTIVE ACTION

Replace Blind Flange Cover (WP 0040).

END OF WORK PACKAGE

**FIELD MAINTENANCE
DRAIN HOSE ASSEMBLY
TROUBLESHOOTING PROCEDURES**

INITIAL SETUP:**Personnel Required**

Quartermaster and Chemical Equipment
Repairer 63J

References

WP 0041

TROUBLESHOOTING PROCEDURES**DRAIN HOSE ASSEMBLY****CAUTION**

To prevent possible flooding, drain Tank Envelope partially before attempting to inspect or replace gaskets or seals.

SYMPTOM

Drain Hose Assembly does not drain properly.

MALFUNCTION

Drain Hose is worn, cracked, or clogged with dirt or grime.

CORRECTIVE ACTION

Service Drain Hose (WP 0041).

END OF WORK PACKAGE

**FIELD MAINTENANCE
DRAIN BALL VALVE ASSEMBLY
TROUBLESHOOTING PROCEDURES**

INITIAL SETUP:**Personnel Required**

Quartermaster and Chemical Equipment
Repairer 63J

References

WP 0042

TROUBLESHOOTING PROCEDURES**DRAIN BALL VALVE ASSEMBLY****SYMPTOM**

Female Coupling leaks.

MALFUNCTION

Female Coupling is cracked, damaged or missing cam-lever arms.

CORRECTIVE ACTION

Replace Female Coupling or missing cam-lever arms (WP 0042).

MALFUNCTION

Female Coupling Gasket is damaged or missing.

CORRECTIVE ACTION

Replace Gasket (WP 0042).

SYMPTOM

Male Coupling leaks.

MALFUNCTION

Male Coupling is cracked, damaged or missing cam-lever arms.

CORRECTIVE ACTION

Replace Male Coupling or missing cam-lever arms (WP 0042).

DRAIN BALL VALVE ASSEMBLY – CONTINUED

SYMPTOM

Drain Valve housing leaks.

MALFUNCTION

Drain Valve housing is cracked or damaged.

CORRECTIVE ACTION

Replace Drain Valve (WP 0042).

END OF WORK PACKAGE

**FIELD MAINTENANCE
FILLER/DISCHARGE BALL VALVE ASSEMBLY
TROUBLESHOOTING PROCEDURES**

INITIAL SETUP:**Personnel Required**

Quartermaster and Chemical Equipment
Repairer 63J

References

WP 0043

TROUBLESHOOTING PROCEDURES**FILLER/DISCHARGE BALL VALVE ASSEMBLY****SYMPTOM**

Female Coupling leaks.

MALFUNCTION

Female Coupling is cracked, damaged or missing cam-locking arms.

CORRECTIVE ACTION

Replace Female Coupling (WP 0043).

MALFUNCTION

Female Coupling is damaged or missing Gasket.

CORRECTIVE ACTION

Replace Gasket (WP 0043).

SYMPTOM

Male Coupling leaks.

MALFUNCTION

Male Coupling is cracked or damaged.

CORRECTIVE ACTION

Replace Male Coupling (WP 0043).

MALFUNCTION

Male Coupling is damaged or missing Gasket.

CORRECTIVE ACTION

Replace Gasket (WP 0043).

FILLER/DISCHARGE BALL VALVE ASSEMBLY

MALFUNCTION

Filler/Discharge Valve housing is cracked or leaks.

CORRECTIVE ACTION

Replace Filler/Discharge Valve (WP 0043).

END OF WORK PACKAGE

**FIELD MAINTENANCE
FILLER/DISCHARGE HOSE ASSEMBLY
TROUBLESHOOTING PROCEDURES**

INITIAL SETUP:**Personnel Required**

Quartermaster and Chemical Equipment
Repairer 63J

References

WP 0044

TROUBLESHOOTING PROCEDURES**FILLER/DISCHARGE HOSE ASSEMBLY****SYMPTOM**

Hose couplings leak.

MALFUNCTION

Hose leaks or is torn.

CORRECTIVE ACTION

Service Hose (WP 0044).

END OF WORK PACKAGE

CHAPTER 6

**FIELD MAINTENANCE INSTRUCTIONS
FOR
TANK, FABRIC, COLLAPSIBLE, WATER STORAGE,
50,000 GALLON**

**FIELD MAINTENANCE
SERVICE UPON RECEIPT OF MATERIEL**

INITIAL SETUP:**Tools and Special Tools**

Tool kit, general mechanic's (WP 0064, Item 1)

References

DA PAM 750-8
SF 361

Personnel Required

Quartermaster and Chemical Equipment Repairer 63J
Water Treatment Specialist 92W

GENERAL INFORMATION

The following paragraphs contain procedures for unloading, unpacking and general checking of the unpacked Tank Assembly.

Inspect the equipment for damage incurred during shipment. If the equipment has been damaged, report the damage on SF 361, Transportation Discrepancy Report.

Check equipment against the packing slip to ensure that the shipment is complete. Report all discrepancies in accordance with applicable service instructions, DA PAM 750-8.

CAUTION

The Tank Assembly should be assembled on a level area free of debris and large rocks. Special care should be taken to ensure that no hose assemblies are placed on or near rocks or other objects that may have sharp points or edges which may damage the hose assemblies when the water system is operated. Be sure that the site allows for enough room to assemble the water system.

SERVICE UPON RECEIPT OF MATERIEL**NOTE**

Air pockets trapped between Tank Envelope and interior chafing patches sometimes occur during manufacturing. This does not affect the functionality of Tank Assembly.

Inspect the equipment for damage incurred (punctures or tears) during shipment. If the equipment has been damaged, report the damage in accordance with the instructions of DA PAM 750-8.

Check the equipment against the packing slip to see if the shipment is complete. Report all discrepancies in accordance with the instructions of DA PAM 750-8.

Inspect the Emergency Repair Kit that is packaged separately. Place the kit in a secure storage area until required.

Check to see whether the equipment has been modified.

If a special design reusable container is involved for components which are authorized for replacements, instructions shall be prepared to report or reenter the empty container through supply channels. Instructions shall be prepared on how to package the unserviceable component in the empty container in the same manner that the new component was packaged if a component is being replaced.

UNPACKING

Unpack Tank Assembly and refer to shipping documents.

CHECK UNPACKED EQUIPMENT

Table 1. Equipment Inspection.

COMPONENT	ACCEPTABLE	REPAIRABLE	NONREPARABLE
TANK ASSEMBLY COMPONENTS			
Tank Envelope	Free from major damage. NOTE Air pockets trapped between tank envelope and interior chafing patches sometimes occur during manufacturing. This does not affect the functionality of the tank.	Any damage that does not affect serviceability of Tank Envelope.	Major damage that affects serviceability.
Couplings	Minor or corrosion that would not impair serviceability of couplings.	Minor rust or corrosion that can be removed without affecting serviceability of couplings.	Rust, damage, or corrosion that affects serviceability of couplings.
Valve Assemblies	Minor rust or corrosion that would not impair serviceability or valve assemblies.	Minor rust or corrosion that can be removed without affecting serviceability of valve assemblies.	Rust, damage, or corrosion that affects serviceability of valve assemblies.
Hoses	Free of rips and tears.	Damaged or missing dust caps or plugs.	Small pinholes, major rips or tears.

PRELIMINARY SERVICING OF EQUIPMENT

No preliminary servicing or adjustment is required.

END OF TASK**END OF WORK PACKAGE**

**FIELD MAINTENANCE
PREVENTIVE MAINTENANCE CHECKS AND SERVICES (PMCS)
INTRODUCTION**

INTRODUCTION

GENERAL

Systematic, periodic, Preventive Maintenance Checks and Services (PMCS) are essential to ensure that the Tank Assembly is ready for operation at all times. The purpose of a preventive maintenance program is to discover and correct defects and deficiencies before they can cause serious damage or complete failure of the equipment. Any effective preventive maintenance program must begin with the indoctrination of Operators to report all unusual conditions noted during daily checks or actual operation to Field Maintenance. All defects and deficiencies discovered during maintenance inspections must be recorded, together with corrective action taken, on DA Form 2404 (Equipment Inspection and Maintenance Worksheet), or DA Form 5988-E (Equipment Maintenance and Inspection Worksheet). Pay attention to WARNING and CAUTION statements. A WARNING means someone could be injured or killed. A CAUTION means equipment could get damaged.

A schedule for Field Maintenance inspection and service should be established immediately after initial operation of the Tank Assembly. When operating under unusual conditions, such as a very dusty or sandy environment, it may be necessary to reduce the interval to monthly or even less if conditions are extreme.

If you find something wrong when performing PMCS, fix it, if you can, using troubleshooting procedures and/or maintenance procedures.

The right-hand column of the PMCS table lists conditions that make the equipment not fully mission capable. Write up items not-fixed on DA Form 2404 or DA Form 5988-E for Field Maintenance. For further information on how to use these forms, see DA PAM 750-8.

LEAKAGE DEFINITIONS

NOTE

Equipment operation is allowed with minor leakage (Class I or II).

When operating with Class I or II leaks, continue to check drip pans and ensure the leak is not a Class III leak.

If there is a Class III leak, shut down operation immediately, and report it to your supervisor.

It is important to understand how water leakage affects the status of the Tank Assembly. Following are definitions of the leakage classes the operator and mechanic need to become familiar with in order to be able to determine the condition of the leak. Remember, when in doubt, always consult your supervisor.

Leakage Classifications for PMCS:

CLASS I - Seepage of water (as indicated by wetness or discoloration) not great enough to form drops.

CLASS II - Leakage of water great enough to form drops but not enough to cause drops to drip from item being inspected.

CLASS III - Leakage of water great enough to form drops that fall from the item being inspected.

INSPECTION

Look for signs of a problem or trouble. You can feel, smell, hear or see many problems. Be alert when using the equipment.

Inspect to ensure items are in good condition, correctly assembled, properly lubricated, stowed, secured, and not excessively worn, leaking, or corroded.

The following are common items to check throughout the equipment:

1. Bolts, clamps, nuts and Screws: Continually check for looseness. Look for chipped paint, bare metal, rust or corrosion around bolt and Screw heads and nuts; tighten when loose.
2. Hoses: Look for wear, damage and leaks. Ensure that clamps and fittings are tight. Wet spots indicate leakage. A stain near a fitting or connector can also indicate leakage. If a leak is discovered, repair as required.

CLEANING**WARNING**

Follow all cleaning instructions carefully. Failure to comply can result in damage to equipment or injury to personnel.

Thoroughly wash all equipment exposed to salt and spray with clean, fresh water.

CORROSION PREVENTION AND CONTROL (CPC)

Corrosion Prevention and Control (CPC) of Army materiel is a continuing concern. It is important that any corrosion problems with this item be reported so corrections and improvements can be made to prevent problems in future items.

Corrosion is typically associated with rusting of metals or galvanic corrosion, which produces a white powder. Corrosion also includes deterioration of other materials, such as rubber and plastic. Unusual cracking, softening, swelling or breaking of the materials may indicate corrosion problems. If a corrosion problem is identified, it can be reported using SF 368 Product Quality Deficiency Report. Use of key words, such as "corrosion," "rust," "deterioration," or "cracking," will ensure that the information is identified as a CPC problem. The form should be submitted to the address specified in DA PAM 750-8.

ARMY OIL ANALYSIS PROGRAM (AOAP)

This Tank Assembly is not enrolled in the Army Oil Analysis Program.

END OF TASK

END OF WORK PACKAGE

**FIELD MAINTENANCE
PREVENTIVE MAINTENANCE CHECKS AND SERVICES (PMCS) AND
LUBRICATION PROCEDURES**

INITIAL SETUP:

Tools and Special Tools

Tool kit, general mechanic's (WP 0064, Item 1)

References

WP 0002
WP 0004

Personnel Required

Quartermaster and Chemical Equipment
Repairer 63J

PMCS PROCEDURES

NOTE

Refer to WP 0002 and WP 0004 for location of components.

Table 1. Preventive Maintenance Checks and Services (PMCS).

ITEM NO.	INTERVAL	ITEM TO BE CHECKED OR SERVICED	PROCEDURE	EQUIPMENT NOT READY/ AVAILABLE IF:
1	Quarterly	Tank Envelope	<ol style="list-style-type: none"> 1. Inspect for cuts, punctures, and leaks. 2. Check for loose or missing bolts where fittings connect to Tank Envelope. 	<p>Tank Envelope is cut, punctured, or leaks.</p> <p>Loose or missing bolts.</p>
2	Quarterly	Filler/Discharge Ball Valve Assembly	<ol style="list-style-type: none"> 1. Check Filler/Discharge Ball Valve Assembly for proper operation and ensure no leaks. 2. Check for bent, broken, or binding parts. 	<p>Filler/Discharge Valve will not open/close or leaks.</p> <p>Component parts are missing or damaged.</p>
3	Quarterly	Vent Fitting Assembly	<ol style="list-style-type: none"> 1. Inspect for evidence of leaks. 2. Check vent cap for cleanliness and freedom of operation. 3. Check Vent Cap and ensure cam-lever arms are not damaged or missing. 	<p>Any evidence of leaks.</p> <p>Vent Cap missing or cam-lever arms are damaged or missing.</p>

PMCS PROCEDURES – CONTINUED

Table 1. Preventive Maintenance Checks and Services (PMCS) – Continued.

ITEM NO.	INTERVAL	ITEM TO BE CHECKED OR SERVICED	PROCEDURE	EQUIPMENT NOT READY/ AVAILABLE IF:
4	Quarterly	Filler/Discharge Elbow	<ol style="list-style-type: none"> 1. Check for evidence of damage. 2. Check if cam-lever arms are damaged or missing. 3. Check if elbow body is cracked or sealing surface is badly dented. 4. Check for loose, damaged, or missing screws and gaskets. 	<p>Evidence of damage.</p> <p>Cam-lever arms are damaged or missing.</p> <p>Filler/Discharge Elbow or sealing surface is badly dented or cracked.</p> <p>Hardware is loose, damaged, or missing screws or gaskets.</p>
5	Quarterly	Drain Fitting Assembly	Inspect for missing gaskets or damaged coupling arms.	Gaskets missing or damaged coupling arms.
6	Quarterly	Emergency Repair Kit	Check for missing components. Replace missing components.	
7	Semi-Annually	Drain Fitting Assembly	<ol style="list-style-type: none"> 1. Check immediate area for evidence of leaks. 2. Check Drain Hose and liner ball valve for damaged or missing parts. 	<p>Any evidence of leaks.</p> <p>Drain Hose or liner ball valve are missing parts, improperly connected, or damaged.</p>

Lubrication Procedures

Lubrication is not applicable to this equipment.

END OF WORK PACKAGE

**FIELD MAINTENANCE
TANK ASSEMBLY
SERVICE AND REPLACEMENT**

INITIAL SETUP:

Tools and Special Tools

Tool kit, general mechanic's (WP 0064, Item 1)

Personnel Required

Quartermaster and Chemical Equipment Repairer 63J

Materials/Parts

Detergent, general purpose (WP 0067, Item 2)
Rags, wiping (WP 0067, Item 4)

References

WP 0038
WP 0039
WP 0040

Equipment Condition

Tank Envelope Drained

REMOVAL

1. Remove Vent Fitting Assembly (Figure 1, Item 1) from vent fitting (Figure 1, Item 2) (WP 0038).
2. Remove Filler/Discharge Assemblies (Figure 1, Item 3) (WP 0039).
3. Remove Drain Fitting Assembly (Figure 1, Item 4) (WP 0040).
4. Dispose of Tank Envelope (Figure 1, Item 5) in accordance with Unit Standing Operating Procedures.

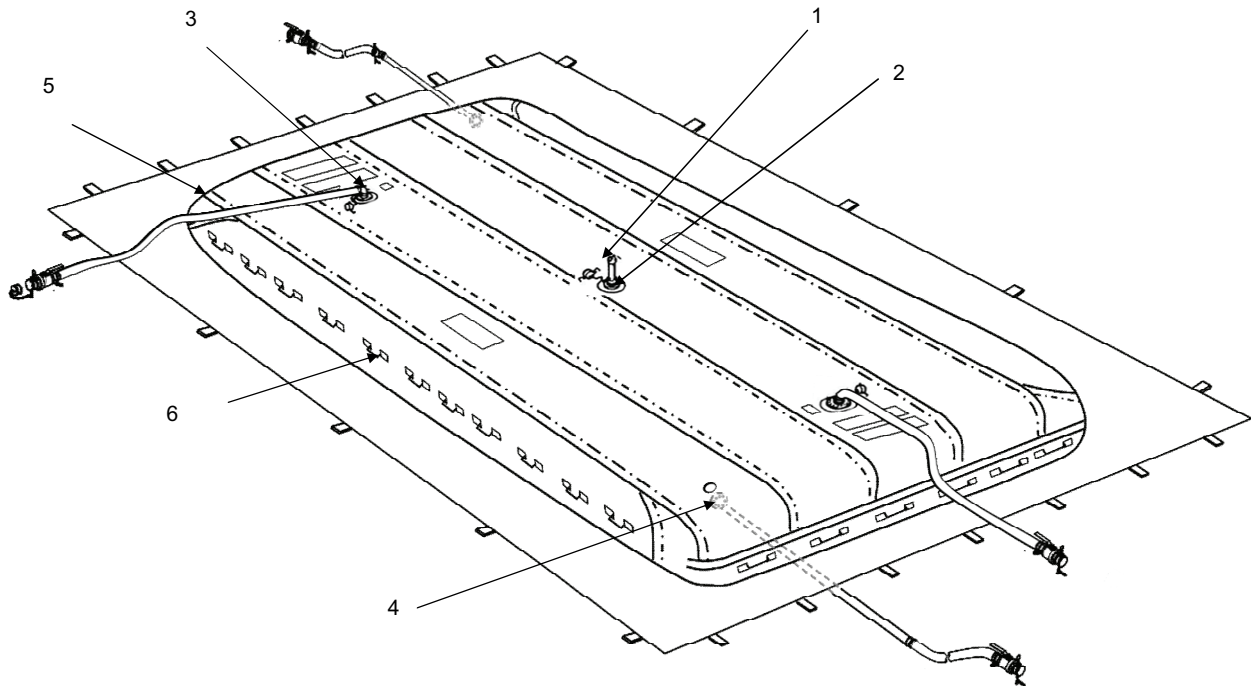

Figure 1. Tank Assembly.

SERVICE

1. Clean all mechanical parts with general purpose detergent (WP 0067, Item 2) and dry thoroughly with wiping rags (WP 0067, Item 4).
2. Clean Tank Envelope (Figure 1, Item 5) exterior with general purpose detergent (WP 0067, Item 2) and water.
3. Inspect all mechanical parts for cracks, dents, breaks, and wear.
4. Replace components if unserviceable.

END OF TASK**INSTALLATION****NOTE**

Prior to installation of Tank Assembly, drain end of Tank Envelope (Figure 1, Item 5) will unroll first.

1. Unroll Tank Envelope (Figure 1, Item 5) and unfold sides using Tank Envelope handles (Figure 1, Item 6) to position Tank Envelope (Figure 1, Item 5).
2. Install Tank Envelope Drain Fitting Assembly (Figure 1, Item 4) (WP 0040).
3. Install Filler/Discharge Assemblies (WP 0039).
4. Install Vent Fitting Assembly (Figure 1, Item 1) (WP 0038).
5. Add water to Tank Assembly and check for leaks.

END OF TASK**END OF WORK PACKAGE**

**FIELD MAINTENANCE
TANK ENVELOPE
INSPECT**

INITIAL SETUP:**Personnel Required**

Quartermaster and Chemical Equipment
Repairer 63J

Reference

WP 0006

INSPECT

Field maintenance on Tank Envelope is limited to inspection and emergency repairs (WP 0006).

END OF WORK PACKAGE

**FIELD MAINTENANCE
VENT FITTING ASSEMBLY
SERVICE AND REPAIR**

INITIAL SETUP:**Tools and Special Tools**

Tool kit, general mechanic's (WP 0064, Item 1)
Wrench, torque (WP 0064, Item 2)

Personnel Required

Quartermaster and Chemical Equipment
Repairer 63J

Materials/Parts

Detergent, general purpose (WP 0067, Item 2)
Rags, wiping (WP 0067, Item 4)
Silicone Compound (WP 0067, Item 6)
Tape, antiseizing (WP 0067, Item 7)
Gasket (2) (WP 0068, Item 1)
O-ring (WP 0068, Item 4)

DISASSEMBLY**Vent Cap**

1. Unscrew Vent Cap (Figure 1, Item 1) from Vent Pipe (Figure 1, Item 2).
2. Hold Vent Pipe (Figure 1, Item 2) in one hand and unscrew Vent Cap (Figure 1, Item 1) with other hand.

Vent Pipe, Flanged Adapter and Dust Cap

1. Open cam-lever arms (Figure 1, Item 4) outward on Coupling Half (Figure 1, Item 3) to release and remove Coupling Half (Figure 1, Item 3).
2. Remove and discard Gasket (Figure 1, Item 13).
3. Unscrew Coupling Half (Figure 1, Item 3) from Vent Pipe (Figure 1, Item 2).
4. Remove eight Screws (Figure 1, Item 8), eight Washers (Figure 1, Item 9), and Flanged Adapter (Figure 1, Item 10) from tank compression fitting (Figure 1, Item 11).
5. Remove Key Ring (Figure 1, Item 14) from Flanged Adapter (Figure 1, Item 10).
6. Remove O-ring (Figure 1, Item 12) from tank compression fitting (Figure 1, Item 11) and discard.
7. Remove Gasket (Figure 1, Item 7) from Dust Cap (Figure 1, Item 6) and discard.
8. Disconnect Chain (Figure 1, Item 5) and Key Ring (Figure 1, Item 14) on Dust Cap (Figure 1, Item 6) and Flanged Adapter (Figure 1, Item 10).

END OF TASK

SERVICE

1. Clean Vent Cap (Figure 1, Item 1) and all components with general purpose detergent (WP 0067, Item 2) and water.
2. Rinse thoroughly in clean water and dry with wiping rag (WP 0067, Item 4).
3. Inspect Vent Cap (Figure 1, Item 1) for dents or damaged threads.
4. Check for freedom of movement. If damaged, replace Vent Cap (Figure 1, Item 1).
5. Inspect all parts for cracks, dents, distortion, breaks, wear, or other damage.
6. If any parts are no longer serviceable, replace before performing installation.
7. Inspect Screws (Figure 1, Item 8) for damaged or distorted threads.
8. If damaged, replace Screws (Figure 1, Item 8).

END OF TASK

Figure 1. Vent Fitting Assembly.

REPAIR

Repair is limited to replacement of damaged components.

END OF TASK**ASSEMBLY****Vent Pipe, Flanged Adapter, and Dust Cap**

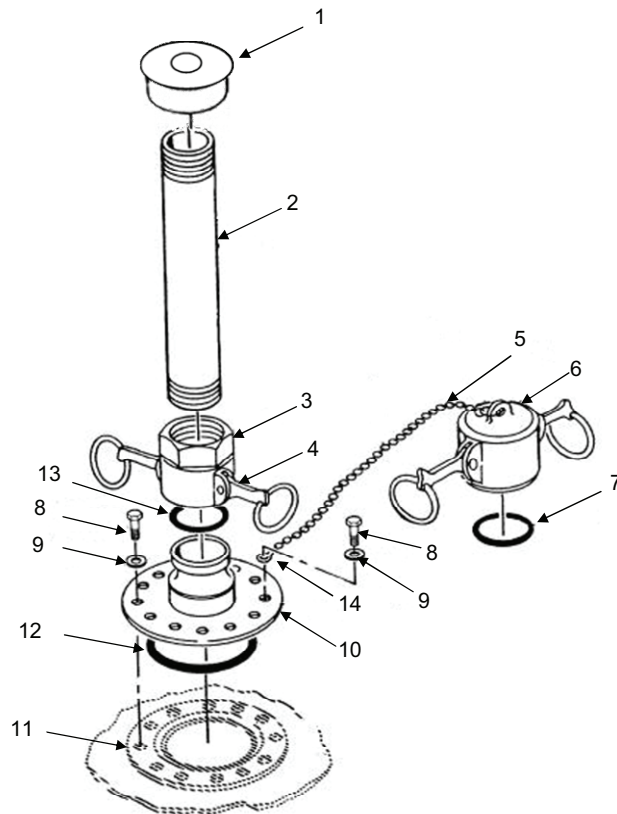
1. Install Chain (Figure 1, Item 5) and Key Rings (Figure 1, Item 14) on Dust Cap (Figure 1, Item 6) and Flanged Adapter (Figure 1, Item 10).
2. Install new Gasket (Figure 1, Item 7) in Dust Cap (Figure 1, Item 6).
3. Coat new O-ring (Figure 1, Item 12) with silicone compound.
4. Position O-ring (Figure 1, Item 12) in groove of Flanged Adapter (Figure 1, Item 10) on Tank Envelope compression fitting (Figure 1, Item 11).
5. Make sure O-ring (Figure 1, Item 12) is properly seated in groove.
6. Install eight Screws (Figure 1, Item 8) and eight Washers (Figure 1, Item 9) through Flanged Adapter (Figure 1, Item 10) and into Tank Envelope compression fitting (Figure 1, Item 11).
7. Torque Screws (Figure 1, Item 8) in sequence to 11 ft•lb (15 N•m).
8. Apply antiseizing tape to threaded ends of Vent Pipe (Figure 1, Item 2).
9. Screw Vent Pipe (Figure 1, Item 2) into Coupling Half (Figure 1, Item 3) until hand tight.
10. Ensure cam-lever arms (Figure 1, Item 4) of Coupling Half (Figure 1, Item 3) are in the same position as they were during removal and disassembly.
11. Install new Gasket (Figure 1, Item 13) in Coupling Half (Figure 1, Item 3), and position Coupling Half (Figure 1, Item 3) onto Flanged Adapter (Figure 1, Item 10).
12. While pushing Coupling Half (Figure 1, Item 3) onto Flanged Adapter (Figure 1, Item 10), close cam-lever arms (Figure 1, Item 4).
13. Ensure Coupling Half (Figure 1, Item 3) is securely locked.

Vent Cap

1. Apply antiseizing tape to threaded ends of Vent Pipe (Figure 1, Item 2).
2. Screw Vent Cap (Figure 1, Item 1) hand tight on Vent Pipe (Figure 1, Item 2).

END OF TASK**END OF WORK PACKAGE**

**FIELD MAINTENANCE
FILLER/DISCHARGE ASSEMBLY
SERVICE AND REPAIR**

INITIAL SETUP:**Tools and Special Tools**

Tool kit, general mechanic's (WP 0064, Item 1)
Wrench, torque (WP 0064, Item 2)

Personnel Required

Quartermaster and Chemical Equipment
Repairer 63J

Materials/Parts

Detergent, general purpose (WP 0067, Item 2)
Rags, wiping (WP 0067, Item 4)
Gasket (8) (WP 0068, Item 6)
Gasket (4) (WP 0068, Item 2)
Gasket (WP 0068, Item 7)
Washer, lock (8) (WP 0068, Item 3)
O-ring (WP 0068, Item 5)

Equipment Condition

Tank Envelope drained (WP 0005)

DISASSEMBLY**CAUTION**

Be sure to take off Compression Plate before removing Flanged Adapter. Flanged Adapter is bolted to Compression Plate and Suction Stub. If Flanged Adapter is removed first, Screws attached to Suction Stub will fall into Tank Envelope.

NOTE

Filler/Discharge fitting on discharge end requires a Discharge Elbow. Filler/Discharge fitting of fill end requires a Filler Elbow.

1. Remove Filler/Discharge Elbow (Figure 1, Item 1) by pulling outward on cam-lever arms (Figure 1, Item 2), and lifting Filler/Discharge Elbow (Figure 1, Item 1) from Flanged Adapter (Figure 1, Item 4).
2. Remove Filler/Discharge Elbow Gasket(s) (Figure 1, Item 3).
 - a. Remove and discard Gasket (Figure 1, Item 3) from inside Discharge Elbow (Figure 1, Item 1).
 - b. Remove and discard Gaskets (Figure 1, Item 3) from inside Filler Elbow (Figure 1, Item 1).
3. Remove Screws (Figure 1, Item 14) and Washers (Figure 1, Item 13) from Compression Plate (Figure 1, Item 5).
4. Lift Compression Plate (Figure 1, Item 5) from Tank Envelope fitting (Figure 1, Item 8).
5. Remove and discard O-ring (Figure 1, Item 7) from packing groove located in Tank Envelope fitting (Figure 1, Item 8).
6. Remove eight Nuts (Figure 1, Item 10), Lock Washers (Figure 1, Item 11), Screws (Figure 1, Item 16), and Gaskets (Figure 1, Item 12) from Suction Stub (Figure 1, Item 9) Flanged Adapter (Figure 1, Item 4), and Gasket (Figure 1, Item 6).
7. Discard Lock Washers (Figure 1, Item 11) and Gaskets (Figure 1, Items 6 and 12).
8. Remove and discard Gasket (Figure 1, Item 3) from inside Dust Cap (Figure 1, Item 15).

SERVICE

1. Clean all parts with general purpose detergent (WP 0067, Item 2) and warm water. Dry thoroughly with wiping rags (WP 0067, Item 4).
2. Clean all gasket-sealing surfaces thoroughly with general purpose detergent (WP 0067, Item 2) and hot water.
3. Inspect Filler/Discharge Elbow (Figure 1, Item 1), Flanged Adapter (Figure 1, Item 4), Compression Plate (Figure 1, Item 5), and Suction Stub (Figure 1, Item 9) for cracks, corrosion, dents, breaks, wear, and broken cam-lever locking arms.
4. Replace components if unserviceable.
5. Inspect Dust Cap (Figure 1, Item 15) for cracks, missing or broken Chain (Figure 1, Item 17) and Key Ring (Figure 1, Item 18).
6. Inspect Screws (Figure 1, Item 14 and 16) for damaged threads.
7. Replace unserviceable parts.

END OF TASK

Figure 1. Filler/Discharge Assembly.

ASSEMBLY

1. Install new Gasket (Figure 1, Item 3) into Dust Cap (Figure 1, Item 15).
2. Install Filler/Discharge Elbow Gasket/s (Figure 1, Item 3).
 - a. Install new Gasket (Figure 1, Item 3) from inside discharge elbow (Figure 1, Item 1).
 - b. Install new Gaskets (Figure 1, Item 3) from inside filler elbow (Figure 1, Item 1).
3. Place Suction Stub (Figure 1, Item 9) on a hard, flat surface with eight bolt holes positioned up.
4. Position new Gaskets (Figure 1, Item 12) over each bolt hole in Suction Stub (Figure 1, Item 9).
5. Position Compression Plate (Figure 1, Item 5), on top of new Gaskets (Figure 1, Item 12), and align holes.
6. Position new Flanged Adapter Gasket(Figure 1, Item 6) on Compression Plate (Figure 1, Item 5), and align.
7. Position Flanged Adapter (Figure 1, Item 3) on Gasket (Figure 1, Item 6), and align holes.
8. Install Screws (Figure 1, Item 16) and new Gaskets (Figure 1, Item 12) through holes in Flanged Adapter (Figure 1, Item 4), thread Screws (Figure 1, Item 16) through until ends protrude through Suction Stub (Figure 1, Item 9).
9. Assemble new Gaskets (Figure 1, Item 12), new Lock Washers (Figure 1, Item 11), and nuts (Figure 1, Item 10) to Screws (Figure 1, Item 16). Torque fastening hardware to 18 ft•lb (21.70 N•m).
10. Install o-ring (Figure 1, Item 7) onto tank fitting (Figure 1, Item 8), and position Compression Plate (Figure 1, Item 5) on tank fitting (Figure 1, Item 8).

NOTE

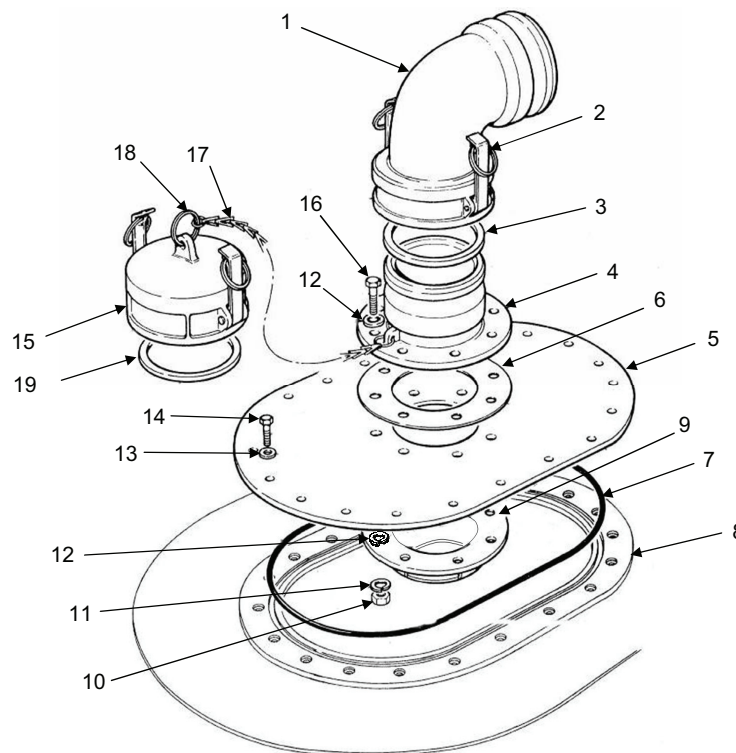
If Tank Envelope is lying completely flat, lift tank to Compression Plate to begin threading Screws through tank fitting.

11. Install Screws (Figure 1, Item 14) through Compression Plate (Figure 1, Item 5) and into tank fitting (Figure 1, Item 8).
12. Torque fastening Screws (Figure 1, Item 14) to 11 ft•lb (15 N•m).
13. Position Filler/Discharge Elbow (Figure 1, Item 1) on Flanged Adapter (Figure 1, Item 4).
14. Push cam-lever arms (Figure 1, Item 2) inward, locking Filler/Discharge Elbow (Figure 1, Item 1) to Flanged Adapter (Figure 1, Item 4).

END OF TASK**END OF WORK PACKAGE**

**FIELD MAINTENANCE
DRAIN FITTING ASSEMBLY
SERVICE AND REPAIR**

INITIAL SETUP:**Tools and Special Tools**

Tool kit, general mechanic's (WP 0064, Item 1)
Wrench, torque (WP 0064, Item 2)
Adapter, socket wrench, 3/8 in. female square
end 1/2 in. male square end (WP 0064, Item 3)

Personnel Required

Quartermaster and Chemical Equipment
Repairer 63J

Materials/Parts

Detergent, general purpose (WP 0067, Item 2)
Rags, wiping (WP 0067, Item 4)
O-Ring (WP 0068, Item 4)

Equipment Condition

Tank Assembly drained (WP 0005)

DISASSEMBLY

1. Remove eight Screws (Figure 1, Item 1) and eight Washers (Figure 1, Item 2) from Drain Fitting (Figure 1, Item 3) and Tank Envelope drain port (Figure 1, Item 5).
2. Remove Blind Flange Cover (Figure 1, Item 3) from Tank Envelope drain port (Figure 1, Item 5) discard if damaged or store for reuse.
3. Remove and discard O-ring (Figure 1, Item 4).

END OF TASK

Figure 1. Drain Fitting Assembly.

SERVICE

1. Clean all parts with general purpose detergent (WP 0067, Item 2) and water, rinse thoroughly, and then dry with wiping rags (WP 0067, Item 4).
2. Mate surfaces thoroughly with general purpose detergent (WP 0067, Item 2) and hot water.
3. Inspect Drain Bowl Fitting (Figure 1, Item 3) for cracks or other damage. If damaged, replace Blind Flange Cover (Figure 1, Item 3).
4. Inspect Blind Flange Cover Screws (Figure 1, Item 1) for distortion or damaged threads. If damaged, replace plate Screws (Figure 1, Item 1).

END OF TASK**REPAIR**

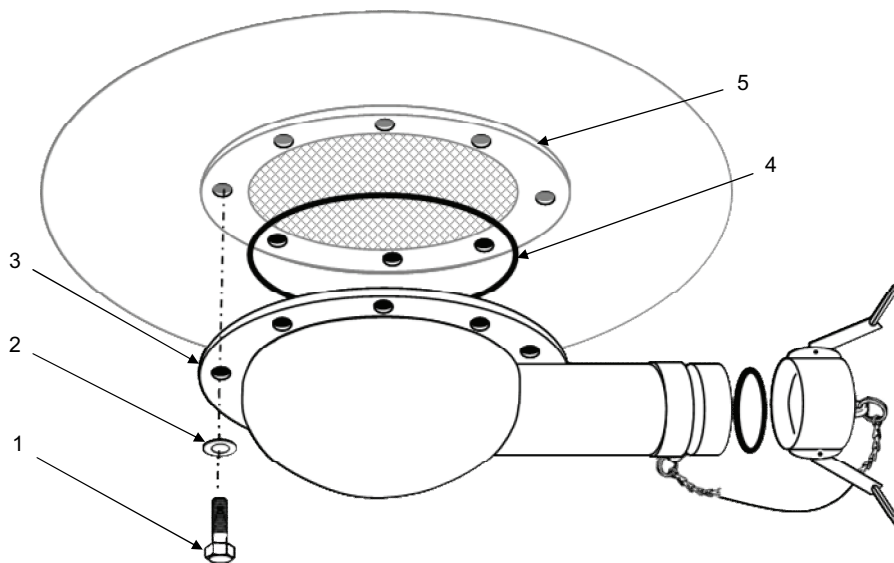
Repair is limited to replacement of damaged components.

END OF TASK**ASSEMBLY****CAUTION**

Failure to replace O-ring could result in leakage and/or damage at the drain port.

1. Position Drain Bowl Fitting (Figure 1, Item 3) and O-ring (Figure 1, Item 4) on tank drain port (Figure 1, Item 5).
2. Install eight Screws (Figure 1, Item 1) and Washers (Figure 1, Item 2), by hand tightening Screws (Figure 1, Item 1).
3. Torque all Screws (Figure 1, Item 1) to 11 ft•lb (15 N•m).
4. Add water to Tank Envelope and check for leaks.

END OF TASK**END OF WORK PACKAGE**

**FIELD MAINTENANCE
DRAIN HOSE ASSEMBLY
SERVICE AND REPAIR**

INITIAL SETUP:**Tools and Special Tools**

Tool kit, general mechanic's (WP 0064, Item 1)

Personnel RequiredQuartermaster and Chemical Equipment
Repairer 63J**Materials/Parts**

Detergent, general purpose (WP 0067, Item 2)

Rag, Wiping (WP 0067, Item 4)

References:

WP 0042

Equipment ConditionTank Assembly drained (WP 0005)

REMOVAL

1. Remove Drain Ball Valve (WP 0042) or Dust Cap (Fig 1, Item 1).

NOTE

It is important to keep Drain Fitting Assembly covered during servicing.

2. Remove Drain Hose Assembly (Figure 1, Item 2) from Drain Fitting Assembly (Figure 1, Item 3).

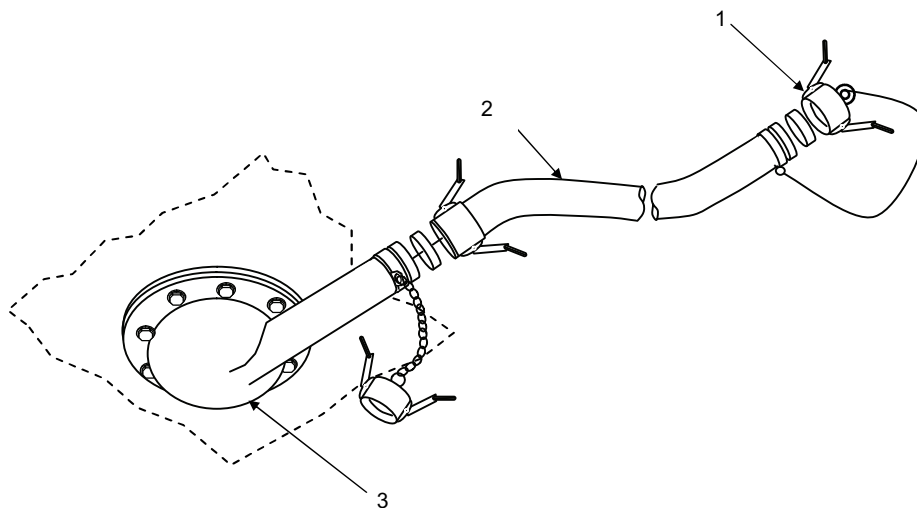

Figure 1. Drain Hose Assembly.

END OF TASK.

SERVICE

1. Flush Drain Hose Assembly (Figure 1, Item 2) with soapy water.
2. Rinse out Drain Hose Assembly (Figure 1, Item 2) thoroughly and air dry.
3. Inspect Drain Hose (Figure 2, Item 1) for cracks, tears, or wear. If cracked, torn, or worn, replace Drain Hose (Figure 2, Item 1).
4. Inspect metallic parts for cracks, damage or missing hardware. If cracked or damaged, replace damaged components and/or missing hardware.
5. Install Drain Hose Assembly (Figure 1, Item 2) by connecting to Drain Fitting Assembly (Figure 1, Item 3).
6. Install Drain Ball Valve Assembly (WP 0042).
7. Add water to Tank Envelope and check for leaks.

END OF TASK**REPAIR****NOTE**

Repair on Drain Hose Assembly is limited to replacement of damaged components.

DISASSEMBLY

1. Pull outward on cam-lever arms (Figure 2, Item 3).
2. Remove Dust Cap (Figure 2, Item 4) from Male Coupling (Figure 2, item 7).
3. Remove Chain (Figure 2, Item 6) and two Key Holders (Figure 2, Item 5) from Dust Cap (Figure 2, Item 4) and Male Coupling (Figure 2, item 7).
4. Remove Gasket (Figure 2, Item 2) from Dust Cap (Figure 2, Item 4). Discard Gasket.
5. Pull outward on cam-lever arms (Figure 2, Item 8).
6. Remove Dust Plug (Figure 2, Item 13) from Female Coupling (Figure 2, Item 9).
7. Remove Chain (Figure 2, Item 10) and two Key Holders (Figure 2, Item 11) from Dust Plug (Figure 2, Item 13) and Female Coupling (Figure 2, Item 9).
8. Remove Gasket (Figure 2, Item 12) in Female Coupling (Figure 2, Item 9). Discard Gasket.

DISASSEMBLY CONTINUED

Figure 2. Drain Hose Assembly.

END OF TASK**ASSEMBLY**

1. Install new Gasket (Figure 2, Item 2) in Female Coupling (Figure 2, Item 9).
2. Push cam-lever arms (Figure 2, Item 3) on Female Coupling (Figure 2, Item 9) outward, away from body of Female Coupling (Figure 2, Item 9).
3. Install Dust Plug (Figure 2, Item 1) in Female Coupling (Figure 2, Item 9).
4. Push cam-lever arms (Figure 2, Item 3) on Female Coupling (Figure 2, Item 9) inward, toward body of Female Coupling (Figure 2, Item 9) until locked.
5. Install new Gasket (Figure 2, Item 6) in Dust Cap (Figure 2, Item 7).
6. Push cam-lever arms (Figure 2, Item 8) on Dust Cap (Figure 2, Item 7) outward, away from body of Dust Cap (Figure 2, Item 7).
7. Install Dust Cap (Figure 2, Item 7) on Male Coupling (Figure 2, Item 5).
8. Push cam-lever arms (Figure 2, Item 8) on Dust Cap (Figure 2, Item 7) inward, toward body of Dust Cap (Figure 2, Item 7) until locked.

END OF TASK**END OF WORK PACKAGE**

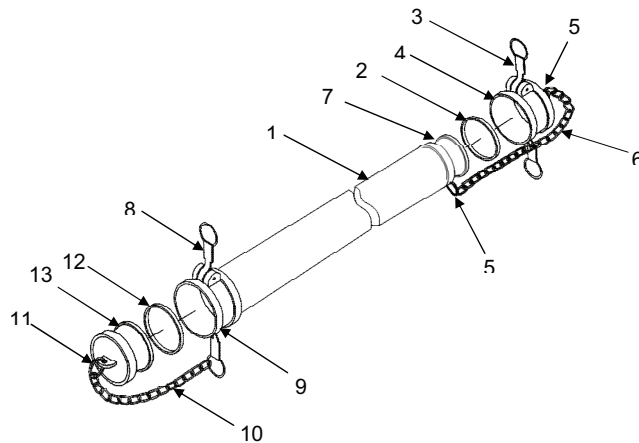
**FIELD MAINTENANCE
DRAIN BALL VALVE ASSEMBLY
SERVICE AND REPAIR**

INITIAL SETUP:**Tools and Special Tools**

Tool kit, general mechanic's (WP 0064, Item 1)

Personnel Required

Quartermaster and Chemical Equipment
Repairer 63J

Materials/Parts

Detergent, general purpose (WP 0067, Item 2)

Rags, wiping (WP 0067, Item 4)

Sealing compound (WP 0067, Item 5)

Tape, antiseizing (WP 0067, Item 7)

Gasket (2) (WP 0068, Item 1)

REMOVAL

Remove Drain Ball Valve (Figure 1, Item 1) from Drain Hose Assembly (Figure 1, Item 2). To release Drain Hose Assembly, pull coupling cam-lever arms (Figure 1, Item 3) on Drain Hose Assembly (Figure 1, Item 2) out, away from Drain Hose Assembly (Figure 1, Item 2).

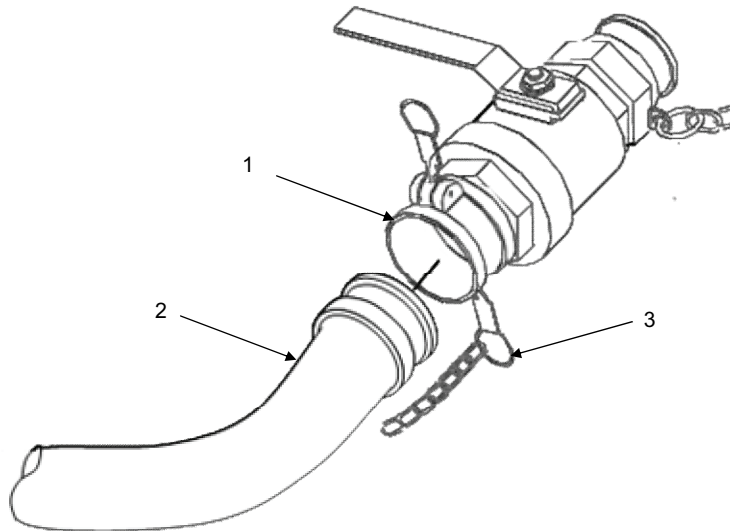

Figure 1. Drain Ball Valve Assembly with Drain Hose.

END OF TASK

DISASSEMBLY

1. Pull cam-lever arms (Figure 2, Item 6) on Dust Cap (Figure 2, Item 5) out, away from body of Dust Cap (Figure 2, Item 5).
2. Remove Dust Cap (Figure 2, Item 5) from Male Coupling (Figure 2, Item 3).
3. Remove and discard Gasket (Figure 2, Item 4) from Dust Cap (Figure 2, Item 5).

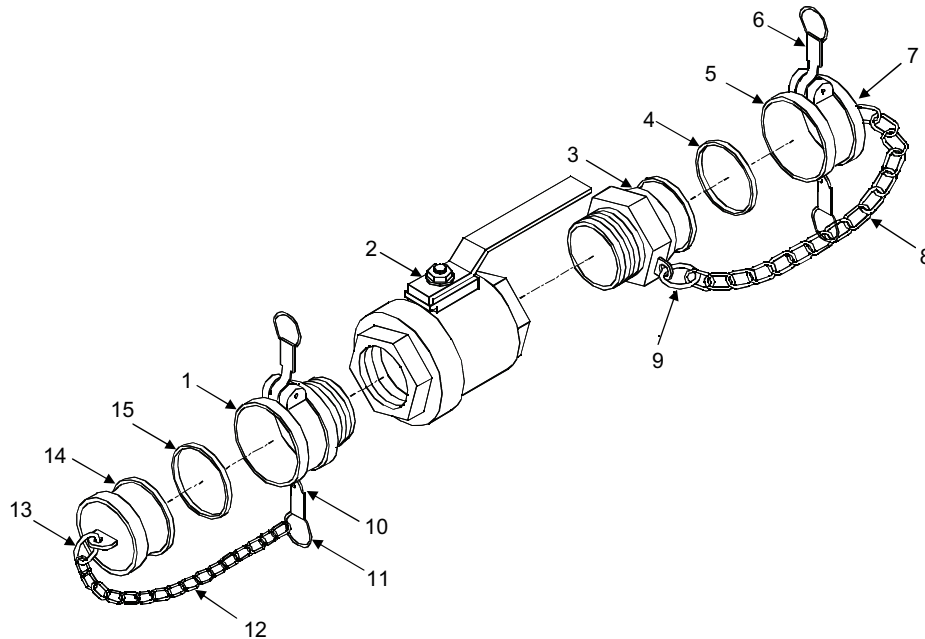

Figure 2. Drain Ball Valve Assembly.

4. Disconnect Chain (Figure 2, Item 8) and two Key Holders (Figure 2, Items 7 and 9) from Dust Cap (Figure 2, Item 5) and Male Coupling (Figure 2, Item 3).
5. Remove Male Coupling (Figure 2, Item 3) from Drain Ball Valve (Figure 2, Item 2).
6. Pull cam-lever arms (Figure 2, Item 10) on Female Coupling (Figure 2, Item 1) out, away from body of Female Coupling (Figure 2, Item 1).
7. Remove Dust Plug (Figure 2, Item 14) from Female Coupling (Figure 2, Item 1).
8. Remove Gasket (Figure 2, Item 15) from Dust Plug (Figure 2, Item 14). Discard Gasket.
9. Disconnect Chain (Figure 2, Item 12) and two Key Holders (Figure 2, Items 11 and 13) from Dust Plug (Figure 2, Item 14) and Female Coupling (Figure 2, Item 1).
10. Remove Female Coupling (Figure 2, Item 1) from Drain Ball Valve (Figure 2, Item 2).

END OF TASK**SERVICE**

1. Clean all parts with general purpose detergent (WP 0067, Item 2) and warm water.
2. Dry thoroughly with wiping rags (WP 0067, Item 4).
3. Inspect all mechanical parts for cracks, dents, breaks, corrosion, and wear.
4. Replace component if unserviceable.

END OF TASK

ASSEMBLY

1. Coat threads of Female Coupling (Figure 2, Item 1) with thread sealing compound (WP 0067, Item 5) or antiseizing tape (WP 0067, Item 7), and install Female Coupling (Figure 2, Item 1) in Drain Ball Valve (Figure 2, Item 2).
2. Connect Chain (Figure 2, Item 12) and two Key Holders (Figure 2, Items 11 and 13) to Dust Plug (Figure 2, Item 14) and Female Coupling (Figure 2, Item 1).
3. Install new Gasket (Figure 2, Item 15) in Female Coupling (Figure 2, Item 1).
4. Push cam-lever arms (Figure 2, Item 10) on Female Coupling (Figure 2, Item 1) outward, away from body of Female Coupling (Figure 2, Item 1).
5. Install Dust Plug (Figure 2, Item 14) in Female Coupling (Figure 2, Item 1).
6. Push cam-lever arms (Figure 2, Item 10) on Female Coupling (Figure 2, Item 1) inward, toward body of Female Coupling (Figure 2, Item 1) until locked.
7. Coat threads of Male Coupling (Figure 2, Item 3) with thread sealing compound (WP 0067, Item 5) or antiseizing tape (WP 0067, Item 7), and install Male Coupling (Figure 2, Item 3) in Drain Ball Valve (Figure 2, Item 2).
8. Connect Chain (Figure 2, Item 8) and two Key Holders (Figure 2, Items 7 and 9) to Male Coupling (Figure 2, Item 3) and Dust Cap (Figure 2, Item 5).
9. Push cam-lever arms (Figure 2, Item 6) on Dust Cap (Figure 2, Item 5) outward, away from body of Dust Cap (Figure 2, Item 5).
10. Install Dust Cap (Figure 2, Item 5) on Male Coupling (Figure 2, Item 3).
11. Push cam-lever arms (Figure 2, Item 6) on Dust Cap (Figure 2, Item 5) inward toward body of Dust Cap (Figure 2, Item 5) until locked.

INSTALLATION

1. Install Drain Ball Valve (Figure 3, Item 1) on Drain Hose Assembly (Figure 3, Item 2).
2. Push male coupling of Drain Hose onto Female Coupling of Drain Valve (Figure 3, Item 1).
3. Push cam-lever arms (Figure 3, Item 3) into position to lock in place.
4. Check for leaks during operation.

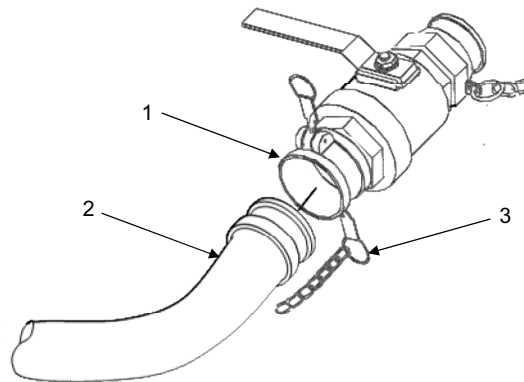

Figure 3. Drain Ball Valve Assembly with Drain Hose.

END OF TASK

END OF WORK PACKAGE

**FIELD MAINTENANCE
FILLER/DISCHARGE BALL VALVE ASSEMBLY
SERVICE AND REPAIR**

INITIAL SETUP:**Tools and Special Tools**

Tool kit, general mechanic's (WP 0064 Item 1)

Personnel Required

Quartermaster and Chemical Equipment
Repairer 63J

Materials/Parts

Detergent, general purpose (WP 0067, Item 2)

Rags, wiping (WP 0067, Item 4)

Sealing compound (WP 0067, Item 5)

Tape, antiseizing (WP 0067, Item 5)

Gasket (2) (WP 0068, Item 2)

REMOVAL

Remove Filler/Discharge Ball Valve (Figure 1, Item 1) from Filler/Discharge Hose Assembly (Figure 1, Item 2). To release Filler/Discharge Hose, pull coupling cam-lever arms (Figure 1, Item 3) on Filler/Discharge Hose Assembly (Figure 1, Item 2) out, away from Filler/Discharge Hose Assembly (Figure 1, Item 2).

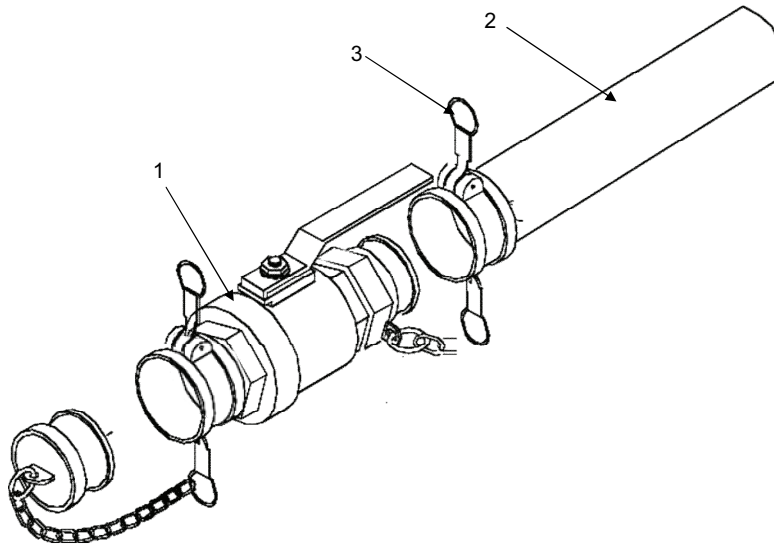

Figure 1. Filler/Discharge Ball Valve and Hose Assembly.

END OF TASK

DISASSEMBLY

1. Pull cam-lever arms (Figure 2, Item 2) on Dust Cap (Figure 2, Item 3) out, away from body of Dust Cap (Figure 2, Item 3).
2. Remove Dust Cap (Figure 2, Item 3) from Male Coupling (Figure 2, Item 5).
3. Remove Gasket (Figure 2, Item 4) from Dust Cap (Figure 2, Item 3). Discard Gasket.

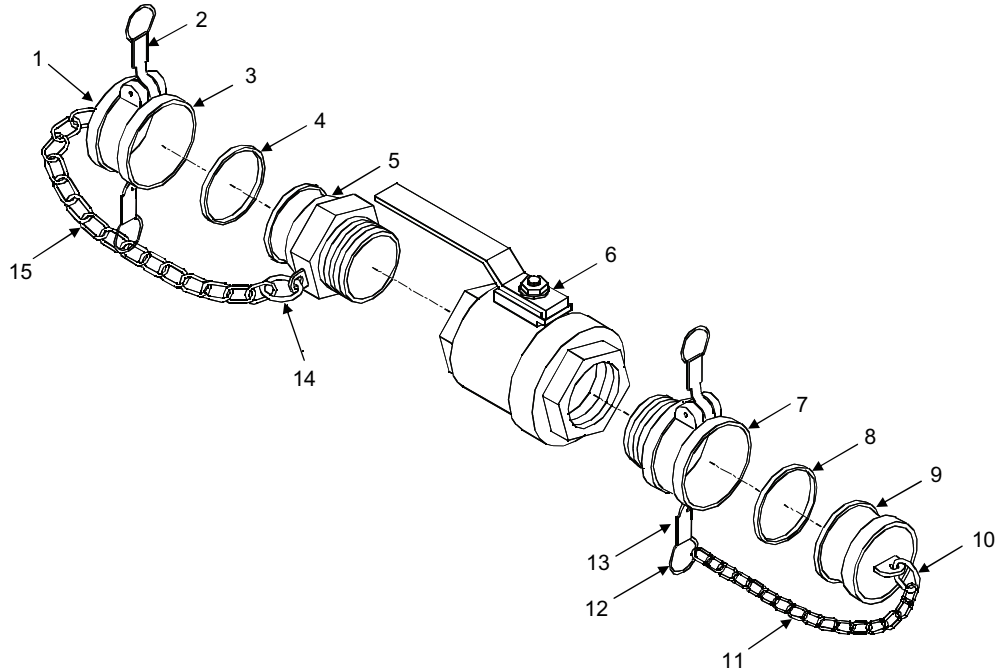

Figure 2. Filler/Discharge Ball Valve Assembly.

4. Disconnect Chain (Figure 2, Item 15) and two Key Holders (Figure 2, Items 1 and 14) from Dust Cap (Figure 2, Item 3) and Male Coupling (Figure 2, Item 5).
5. Remove Male Coupling (Figure 2, Item 5) from Filler/Discharge Ball Valve (Figure 2, Item 6).
6. Pull cam-lever arms (Figure 2, Item 13) on Female Coupling (Figure 2, Item 7) outward, away from body of Female Coupling (Figure 2, Item 7).
7. Remove Dust Plug (Figure 2, Item 9) from Female Coupling (Figure 2, Item 7).
8. Remove Gasket (Figure 2, Item 8) from Female Coupling (Figure 2, Item 7).
9. Disconnect Chain (Figure 2, Item 11) and two Key Holders (Figure 2, Items 10 and 12) from Dust Plug (Figure 2, Item 9) and Female Coupling (Figure 2, Item 7).
10. Remove Female Coupling (Figure 2, Item 7) from Filler/Discharge Ball Valve (Figure 2, Item 6).

END OF TASK**SERVICE**

1. Clean all parts with general purpose detergent (WP 0067, Item 2) and warm water.
2. Dry thoroughly with wiping rags (WP 0067, Item 4).
3. Inspect all mechanical parts for cracks, dents, breaks, corrosion, and wear. Replace component if unserviceable.

END OF TASK

ASSEMBLY

1. Coat threads of Female Coupling (Figure 2, Item 7) with thread sealing compound (WP 0067, Item 5) or antiseizing tape (WP 0067, Item 7), and install Female Coupling (Figure 2, Item 7) in Filler/Discharge Ball Valve (Figure 2, Item 6).
2. Connect Chain (Figure 2, Item 11) and two Key Holders (Figure 2, Items 10 and 12) to Dust Plug (Figure 2, Item 9) and Female Coupling (Figure 2, Item 7).
3. Install new Gasket (Figure 2, Item 8) in Female Coupling (Figure 2, Item 7).
4. Push cam-lever arms (Figure 2, Item 13) on Female Coupling (Figure 2, Item 7) outward, away from body of Female Coupling (Figure 2, Item 7).
5. Install Dust Plug (Figure 2, Item 9) in Female Coupling (Figure 2, Item 7).
6. Push cam-lever arms (Figure 2, Item 13) on Female Coupling (Figure 2, Item 7) inward, toward body of Female Coupling (Figure 2, Item 7) until locked.
7. Coat threads of Male Coupling (Figure 2, Item 5) with thread sealing compound (WP 0067, Item 5) or antiseizing tape (WP 0067, Item 7), and install Male Coupling (Figure 2, Item 5) in Filler/Discharge Ball Valve (Figure 2, Item 6).
8. Connect chain (Figure 2, Item 15) and two Key Holders (Figure 2, Items 1 and 14) to Male Coupling (Figure 2, Item 5) and Dust Cap (Figure 2, Item 3).
9. Install new Gasket (Figure 2, Item 4) in Dust Cap (Figure 2, Item 3).
10. Push cam-lever arms (Figure 2, Item 2) on Dust Cap (Figure 2, Item 3) outward, away from body of Dust Cap (Figure 2, Item 3).
11. Install Dust Cap (Figure 2, Item 3) on Male Coupling (Figure 2, Item 5).
12. Push cam-lever arms (Figure 2, Item 2) on Dust Cap (Figure 2, Item 3) inward toward body of Dust Cap (Figure 2, Item 3) until locked.

END OF TASK

INSTALLATION

1. Install Filler/Discharge Ball Valve (Figure 3, Item 1) on Filler/Discharge Hose Assembly (Figure 3, Item 2).
2. Push Filler/Discharge Hose Assembly coupling onto appropriate coupling of Drain Ball Valve (Figure 3, Item 1).
3. Push cam-lever arms (Figure 3, Item 3) into position to lock in place.
4. Check for leaks during operation.

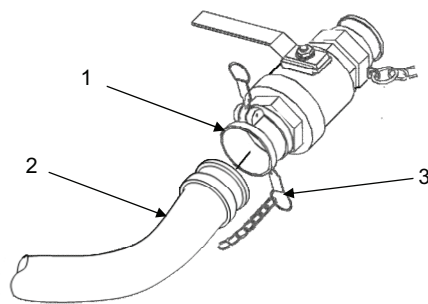

Figure 3. Filler/Discharge Ball Valve Assembly with Hose

END OF TASK

END OF WORK PACKAGE

**FIELD MAINTENANCE
FILLER/DISCHARGE HOSE ASSEMBLY
SERVICE AND REPAIR**

INITIAL SETUP:**Tools and Special Tools**

Tool kit, general mechanic's (WP 0064, Item 1)

Personnel Required

Quartermaster and Chemical Equipment
Repairer 63J

Materials/Parts

Detergent, general purpose (WP 0067, Item 2)

Gasket (2) (WP 0068, Item 2)

NOTE

Repair of Filler/Discharge Hose Assembly is limited to replacement of damaged components.

DISASSEMBLY

1. Pull outward on cam-lever arms (Figure 1, Item 3).
2. Remove Dust Cap (Figure 1, Item 4) from Male Coupling (Figure 1, item 7).
3. Remove Gasket (Figure 1, Item 2) from Dust Cap (Figure 1, Item 4). Discard Gasket.
4. Remove Chain (Figure 1, Item 6) and two Key Holders (Figure 1, Item 5) from Dust Cap (Figure 1, Item 4) and Male Coupling (Figure 1, item 7).
5. Pull outward on cam-lever arms (Figure 1, Item 8).
6. Remove Dust Plug (Figure 1, Item 13) from Female Coupling (Figure 1, Item 9).
7. Remove Chain (Figure 1, Item 10) and two Key Holders (Figure 1, Item 11) from Dust Plug (Figure 1, Item 13) and Female Coupling (Figure 1, Item 9).
8. Remove Gasket (Figure 1, Item 12) from Female Coupling (Figure 1, Item 9). Discard Gasket.

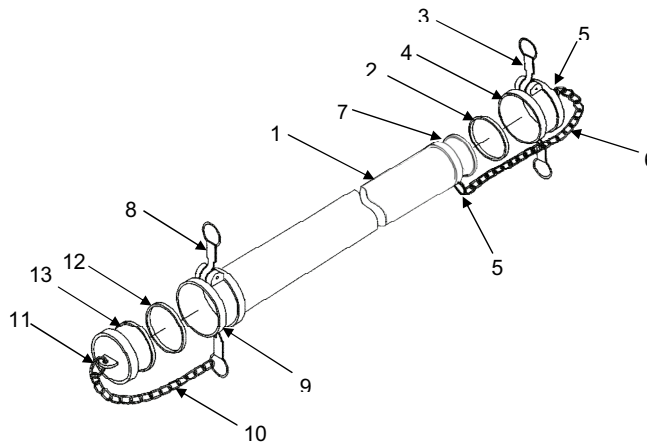

Figure 1. Filler/Discharge Hose Assembly

END OF TASK.

SERVICE

1. Flush out Filler/Discharge Hose Assembly with soapy water.
2. Rinse out Filler/Discharge Hose Assembly thoroughly and air-dry.
3. Inspect Filler/Discharge Hose (Figure 1, Item 1) for cracks, tears, or wear. If cracked, torn, or worn, replace Filler/Discharge Hose (Figure 1, Item 1).
4. Ensure hose bands are secured to couplings.
5. Inspect metallic parts for cracks, damage or missing hardware. If cracked or damaged, replace damaged components and/or missing hardware.
6. Replace any unserviceable components.

END OF TASK**ASSEMBLY**

1. Install Chain (Figure 1, Item 10) and two Key Holders (Figure 1, Item 11) on Dust Plug (Figure 1, Item 13) and Female Coupling (Figure 1, Item 9).
2. Install new Gasket (Figure 1, Item 12) in Female Coupling (Figure 1, Item 9).
3. Push cam-lever arms (Figure 1, Item 8) on Female Coupling (Figure 1, Item 9) outward, away from body of Female Coupling (Figure 1, Item 9).
4. Install Dust Plug (Figure 1, Item 13) in Female Coupling (Figure 1, Item 9).
5. Push cam-lever arms (Figure 1, Item 8) on Female Coupling (Figure 1, Item 9) inward, toward body of Female Coupling (Figure 1, Item 9) until locked.
6. Install Chain (Figure 1, Item 6) and two Key Holders (Figure 1, Item 5) on Dust Cap (Figure 1, Item 4) and Male Coupling (Figure 1, Item 7).
7. Install new Gasket (Figure 1, Item 2) in Dust Cap (Figure 1, Item 4).
8. Push cam-lever arms (Figure 1, Item 3) on Dust Cap (Figure 1, Item 4) outward, away from body of Dust Cap (Figure 1, Item 4).
9. Install Dust Cap (Figure 1, Item 3) on Male Coupling (Figure 1, Item 7).
10. Push cam-lever arms (Figure 1, Item 3) on Dust Cap (Figure 1, Item 4) inward, toward body of Dust Cap (Figure 1, Item 4) until locked.

END OF TASK**END OF WORK PACKAGE**

**FIELD MAINTENANCE
GROUND CLOTH
INSPECT AND REPLACE**

INITIAL SETUP:

Personnel Required

Quartermaster and Chemical Equipment
Repairer 63J

INSPECT AND REPLACE

NOTE

Field maintenance on ground cloth is limited to replacement.

Ground cloth must be replaced when badly torn, frayed or it contains many large punctures.

1. Inspect ground cloth for tears, frays, or large punctures.
2. Replace unserviceable ground cloth.

END OF WORK PACKAGE

**FIELD MAINTENANCE
EMERGENCY REPAIR KIT
INSPECT AND REPLACE**

INITIAL SETUP:

Personnel Required

Quartermaster and Chemical Equipment
Repairer 63J

References

WP 0059

INSPECT AND REPLACE

NOTE

Field Maintenance of Emergency Repair Kit is limited to replacement of missing or damaged components.

1. Inspect Mechanical Patches for missing plates, gaskets, wing nuts and bent or stripped threaded rods. Inventory Emergency Repair Kit to determine if parts are missing (WP 0059).
2. Replace missing or damaged components as required.

END OF WORK PACKAGE

**FIELD MAINTENANCE
TANK, FABRIC, COLLAPSIBLE, WATER STORAGE, 50,000 GALLON
PREPARATION FOR STORAGE OR SHIPMENT**

INITIAL SETUP:**Materials/Parts**

Detergent, general purpose (WP 0067, Item 2)

References

TB Med 577	WP 0038
WP 0002	WP 0039
WP 0005	WP 0041

Personnel Required

Water Treatment Specialist 92W
Quartermaster and Chemical Equipment
Repairer 63J

PREPARATION FOR STORAGE OR SHIPMENT**CAUTION**

Always handle Tank Envelope carefully. Pad components stored with Tank Envelope to avoid chafing during storage or transportation. Rough handling or careless storage can damage Tank Envelope.

NOTE

Prior to storage Tank Envelope should be disassembled, cleaned, and preserved with all its components for future use.

1. Drain water from Tank Envelope (WP 0005).
2. Remove Drain Hose Assembly from Drain Fitting Assembly (WP 0041).
3. Install Dust Cap on Drain Fitting Assembly.
4. Remove Filler/Discharge Elbows from Flanged Adapters (WP 0039).
5. Remove Vent Fitting Assembly from Flanged Adapter, and install Dust Cap (WP 0038).
6. Remove Filler/Discharge Assembly from Tank Envelope (WP 0039).

NOTE

Tank Envelope interior requires little cleaning and should be cleaned only if required.

7. Flush Tank Envelope with general purpose detergent (WP 0067, Item 2) solution.
 - a. Fill Tank Envelope with roughly 300 to 500 gallons of general purpose detergent (WP 0067, Item 2) solution. Follow the instructions on the general purpose detergent to determine the quantity required to prepare 300 to 500 gallons of solution.
 - b. Circulate solution around the tank by lifting the side of the tank and folding one side of the tank over the other. Repeat for each side of the tank and each end.

PREPARATION FOR STORAGE OR SHIPMENT – CONTINUED**NOTE**

Contact unit/local safety office for disposal of cleaning residue.

8. Drain general purpose detergent (WP 0067, Item 2) solution from Tank Envelope.
9. Squeeze excess detergent solution from Tank Envelope by rolling ends of Tank Envelope towards Tank Drain Fitting.
10. Flush Tank Envelope with clean water.
11. Dry out Tank Envelope by purging it with air pressure. Use a maximum line pressure of 50 lb/sq in. (3.40 atm).
 - a. Insert air hose through Flanged Adapter, placing wiping rags around the air hose at fitting to prevent air from escaping.
 - b. Apply compressed air into Tank Envelope until it expands to 3 ft (0.914 m) in height.
 - c. Remove Dust Cap from Flanged Adapter to allow air to vent from Tank Envelope for 30 minutes.
 - d. Deactivate compressed air source and remove air hose and wiping rags (WP 0067, Item 4).
12. Install Filler/Discharge Assembly on Tank Envelope (WP 0039).
13. Install Dust Caps on Flanged Adapters of Filler/Discharge Assemblies.
14. Brush off all debris clinging to fabric material of Tank Envelope.
15. Fold Tank Envelope from sides towards middle.
16. Roll Tank Envelope from end opposite drain fitting.
17. Plug exposed hose assembly openings with suitable, clean materials.
18. Perform cleaning and sanitizing procedures outlined in TM Med 577 prior to placing it back in use, if Tank Envelope is not going to be used for more than 30 days after it is dry.

END OF TASK**CRATING INSTRUCTIONS**

1. Ensure Tank Envelope has been properly folded (WP 0005).

CAUTION

Use care when packing Tank Envelope. Tank Envelope will be easily damaged by tools, packing box nails, or other sharp objects.

NOTE

Pack Tank Envelope in a box or container. When Tank Envelope is disassembled and re-folded, it is to be replaced in original box or container.

2. Each Tank Envelope is provided with suitable packing around tank to prevent Tank Envelope fabric from being damaged by contact with inside of box or container.
3. When Tank Envelope is replaced in original box or container, packing material is replaced around Tank Envelope in same manner as received.

END OF TASK**END OF WORK PACKAGE**

CHAPTER 7

**PARTS INFORMATION
FOR
TANK, FABRIC, COLLAPSIBLE, WATER STORAGE,
50,000 GALLON**

**FIELD MAINTENANCE
TANK, FABRIC, COLLAPSIBLE, WATER STORAGE, 50,000 GALLON**

INTRODUCTION

SCOPE

This RPSTL lists and authorizes spares and repair parts; special tools; special test, measurement, and diagnostic equipment (TMDE); and other special support equipment required for performance of field maintenance of the Collapsible Fabric Tank, Water Storage. It authorizes the requisitioning, issue, and disposition of spares, repair parts, and special tools as indicated by the source, maintenance, and recoverability (SMR) codes.

GENERAL

In addition to the Introduction Work Package, this RPSTL is divided into the following work packages:

1. Repair Parts List Work Packages. Work packages containing lists of spares and repair parts authorized by this RPSTL for use in the performance of maintenance. These work packages also include parts which must be removed for replacement of the authorized parts. Parts lists are composed of functional groups in ascending alphanumeric sequence, with the parts in each group listed in ascending figure and item number sequence. Sending units, brackets, filters, and bolts are listed with the component they mount on. Bulk materials are listed by item name in FIG. BULK at the end of the work packages.
2. Special Tools List Work Packages. Work packages containing lists of special tools, special TMDE, and special support equipment authorized by this RPSTL (as indicated by Basis of Issue (BOI) information in the DESCRIPTION AND USABLE ON CODE (UOC) column). Tools that are components of common tool sets and/or Class VII are not listed.
3. Cross-Reference Indexes Work Packages. There are two cross-reference indexes work packages in this RPSTL: the National Stock Number (NSN) Index work package, *and* the Part Number (P/N) Index work package. The National Stock Number Index work package refers you to the figure and item number. The Part Number Index work package refers you to the figure and item number.

EXPLANATION OF COLUMNS IN THE REPAIR PARTS LIST AND SPECIAL TOOLS LIST WORK PACKAGES

ITEM NO. (Column (1)). Indicates the number used to identify items called out in the illustration.

SMR CODE (Column (2)). The SMR code containing supply/requisitioning information, maintenance level category authorization criteria, and disposition instruction, as shown in the following breakout. This entry may be subdivided into 4 subentries, one for each service.

Table 1. SMR Code Explanation.

<u>Source Code</u>	<u>Maintenance Code</u>	<u>Recoverability Code</u>
<u>XX</u>	<u>XX</u>	<u>X</u>
1 st two positions: How to get an item.	3 rd position: Who can install, replace or use the item.	4 th position: Who can do complete repair* on the item.
		5 th position: Who determines disposition action on unserviceable items.

* Complete Repair: Maintenance capacity, capability, and authority to perform all corrective maintenance tasks of the "Repair" function in a use/user environment in order to restore serviceability to a failed item.

Source Code. The source code tells you how to get an item needed for maintenance, repair, or overhaul of an end item/equipment. Explanation of source codes follows:

Source Code**Application/Explanation**

PA
PB
PC
PD
PE
PF
PG
PH
PR
PZ

NOTE

Items coded PC are subject to deterioration.

Stock items; use the applicable NSN to request/requisition items with these source codes. They are authorized to the level indicated by the code entered in the third position of the SMR code.

KD
KF
KB

Items with these codes are not to be requested/requisitioned individually. They are part of a kit which is authorized to the maintenance level indicated in the third position of the SMR code. The complete kit must be requisitioned and applied.

MF - Made at Field
MH - Made at below depot/sustainment level
ML - Made at SRA
MD - Made at Depot
MG -Navy Only

Items with these codes are not to be requested/requisitioned individually. They must be made from bulk material which is identified by the part number in the DESCRIPTION AND USABLE ON CODE (UOC) column and listed in the bulk material group of the repair parts list in the RPSTL. If the item is authorized to you by the third position code of the SMR code, but the source code indicates it is made at a higher level, order the item from the higher level of maintenance.

AF-Assembled by field
AH-Assembled by below depot sustainment level
AL-Assembled by SRA
AD-Assembled by depot
AG-Navy only

Items with these codes are not to be requested/requisitioned individually. The parts that make up the assembled item must be requisitioned or fabricated and assembled at the level of maintenance indicated by the source code. If the third position code of the SMR code authorizes you to replace the item, but the source code indicates the item is assembled at a higher level, order the item from the higher level of maintenance.

XA

Do not requisition an XA-coded item. Order its next higher assembly. (Refer to the NOTE below.)

XB

If an XB item is not available from salvage, order it using CAGEC and part number.

XC

Installation drawings, diagrams, instruction sheets, field service drawings; identified by manufacturer's part number.

XD

Item is not stocked. Order an XD-coded item through local purchase or normal supply channels using the CAGEC and part number given, if no NSN is available.

NOTE

Cannibalization or controlled exchange, when authorized, may be used as a source of supply for items with the above source codes, except for those source coded "XA" or those aircraft support items restricted by requirements of AR 750-1.

Maintenance Code. Maintenance codes tell you the level(s) of maintenance authorized to use and repair support items. The maintenance codes are entered in the third and fourth positions of the SMR code as follows:

Third Position. The maintenance code entered in the third position tells you the lowest maintenance level authorized to remove, replace, and use an item. The maintenance code entered in the third position will indicate authorization to the following levels of maintenance.

Maintenance

Code	Application/Explanation
F -	Field maintenance can remove, replace, and use the item.
H -	Below Depot Sustainment maintenance can remove, replace, and use the item.
L -	Specialized repair activity can remove, replace, and use the item.
G -	Afloat and ashore intermediate maintenance can remove, replace, and use the item (Navy only)
K -	Contractor facility can remove, replace, and use the item
Z -	Item is not authorized to be removed, replace, or used at any maintenance level
D -	Depot can remove, replace, and use the item.

*NOTE – Army may use C in the third position. However, for joint service publications, Army will use O.

Fourth Position. The maintenance code entered in the fourth position tells you whether or not the item is to be repaired and identifies the lowest maintenance level with the capability to do complete repair (perform all authorized repair functions).

NOTE

Some limited repair may be done on the item at a lower level of maintenance, if authorized by the Maintenance Allocation Chart (MAC) and SMR codes.

Maintenance

Code	Application/Explanation
F -	Field is the lowest level that can do complete repair of the item.
H -	Below Depot Sustainment is the lowest level that can do complete repair of the item.
L -	Specialized repair activity (enter specialized repair activity or TASMG designator) is the lowest level that can do complete repair of the item.
D -	Depot is the lowest level that can do complete repair of the item.
G -	Both afloat and ashore intermediate levels are capable of complete repair of item. (Navy only)
K -	Complete repair is done at contractor facility
Z -	Nonreparable. No repair is authorized.
B -	No repair is authorized. No parts or special tools are authorized for maintenance of "B" coded item. However, the item may be reconditioned by adjusting, lubricating, etc., at the user level.

Recoverability Code. Recoverability codes are assigned to items to indicate the disposition action on unserviceable items. The recoverability code is shown in the fifth position of the SMR code as follows:

Recoverability

<u>Code</u>	<u>Application/Explanation</u>
Z –	Non-repairable item. When unserviceable, condemn and dispose of the item at the level of maintenance shown in 3rd position of SMR code.
F –	Reparable item. When uneconomically repairable, condemn and dispose of the item at the ASB level.
H –	Reparable item. When uneconomically repairable, condemn and dispose of the item at the general support level.
D –	Reparable item. When beyond lower level repair capability, return to depot. Condemnation and disposal of item not authorized below depot level.
L –	Reparable item. Condemnation and disposal not authorized below Depot level.
A –	Item requires special handling or condemnation procedures because of specific reasons (such as precious metal content, high dollar value, critical material, or hazardous material). Refer to appropriate manuals/directives for specific instructions.
G –	Field level reparable item. Condemn and dispose at either afloat or ashore intermediate levels. (Navy only)
K–	Reparable item. Condemnation and disposal to be performed at Contractor facility.

NSN (Column (3)). The NSN for the item is listed in this column.

CAGEC (Column (4)). The Commercial and Government Entity Code (CAGEC) is a five-digit code which is used to identify the manufacturer, distributor, or Government agency/activity that supplies the item.

PART NUMBER (Column (5)). Indicates the primary number used by the manufacturer (individual, company, firm, corporation, or Government activity), which controls the design and characteristics of the item by means of its engineering drawings, specifications standards, and inspection requirements to identify an item or range of items.

NOTE

When you use an NSN to requisition an item, the item you receive may have a different part number from the number listed.

DESCRIPTION AND USABLE ON CODE (UOC) (Column (6)). This column includes the following information:

1. The Federal item name and, when required, a minimum description to identify the item.
2. Part numbers for bulk materials are referenced in this column in the line item entry for the item to be manufactured/fabricated.
3. Hardness Critical Item (HCI). A support item that provides the equipment with special protection from electromagnetic pulse (EMP) damage during a nuclear attack.
4. The statement END OF FIGURE appears just below the last item description in column (6) for a given figure in both the repair parts list and special tools list work packages.

QTY (Column (7)). The QTY (quantity per figure column) indicates the quantity of the item used in the breakout shown on the illustration/figure, which is prepared for a functional group, subfunctional group, or an assembly. A "V" appearing in this column instead of a quantity indicates that the quantity is variable and the quantity may change from application to application.

EXPLANATION OF CROSS-REFERENCE INDEXES WORK PACKAGES FORMAT AND COLUMNS

1. National Stock Number (NSN) Index Work Package. NSNs in this index are listed in National Item Identification Number (NIIN) sequence.

STOCK NUMBER Column. This column lists the NSN in NIIN sequence. The NIIN consists of the last nine digits of the NSN. When using this column to locate an item, ignore the first 4 digits of the NSN. However, the complete NSN should be used when ordering items by stock number. For example, if the NSN is 4730-00-938-7997, the NIIN is 00-938-7997.

FIG. Column. This column lists the number of the figure where the item is identified/located. The figures are in numerical order in the repair parts and special tools list work packages.

ITEM Column. The item number identifies the item associated with the figure listed in the adjacent FIG. column. This item is also identified by the NSN listed on the same line.

2. Part Number (P/N) Index Work Package. Part numbers in this index are listed by part number in ascending alphanumeric sequence (vertical arrangement of letter and number combinations which places the first letter or digit of each group in order A through Z, followed by the numbers 0 through 9 and each following letter or digit in like order).

PART NUMBER Column. Indicates the part number assigned to the item.

FIG. Column. This column lists the number of the figure where the item is identified/located in the repair parts list and special tool list work packages.

ITEM Column. The item number is that number assigned to the item as it appears in the figure referenced in the adjacent figure number column.

SPECIAL INFORMATION

Fabrication Instructions. Bulk materials required to manufacture items are listed in the bulk material functional group of this RPSTL. Part numbers for bulk material are also referenced in the Description Column of the line item entry for the item to be manufactured/fabricated. Detailed fabrication instructions for items source coded to be manufactured or fabricated are found in TM 10-5430-258-13&P.

Index Numbers. Items which have the word BULK in the figure column will have an index number shown in the item number column. This index number is a cross-reference between the National Stock Number/Part Number Index and the bulk material list in the repair parts list work packages.

Associated Publications. N/A

Illustrations List. The illustrations in this RPSTL contain field authorized items. Illustrations published in TM 10-5430-258-13&P, that contain unit authorized items also appear in the RPSTL. The tabular list in the repair parts list work package contains only those parts coded "F" in the third position of the SMR code, therefore, there may be a break in the item number sequence.

HOW TO LOCATE REPAIR PARTS

1. When NSNs or Part Number is Not Known.

First. Using the table of contents, determine the assembly group or subassembly group to which the item belongs. This is necessary since figures are prepared for assembly groups and subassembly groups, and listings are divided into the same groups.

Second. Find the figure covering the assembly group or subassembly group to which the item belongs.

Third. Identify the item on the figure and note the number(s).

Fourth. Look in the repair parts list work packages of the figure and item numbers. The NSNs and part numbers are on the same line as the associated item numbers.

2. When NSN is known.

First. If you have the NSN look in the STOCK NUMBER column of the NSN index work package. The NSN is arranged in NIIN sequence. Note the figure and item number next to the NSN.

Second. Turn to the figure and locate the item number. Verify that the item is the one you are looking for.

3. When Part Number is known.

First. If you have the part number and not the NSN, look in the PART NUMBER column of the part number index work package. Identify the figure and item number.

Second. Look up the item on the figure in the applicable repair parts list work packages.

FIELD MAINTENANCE
TANK ASSEMBLY

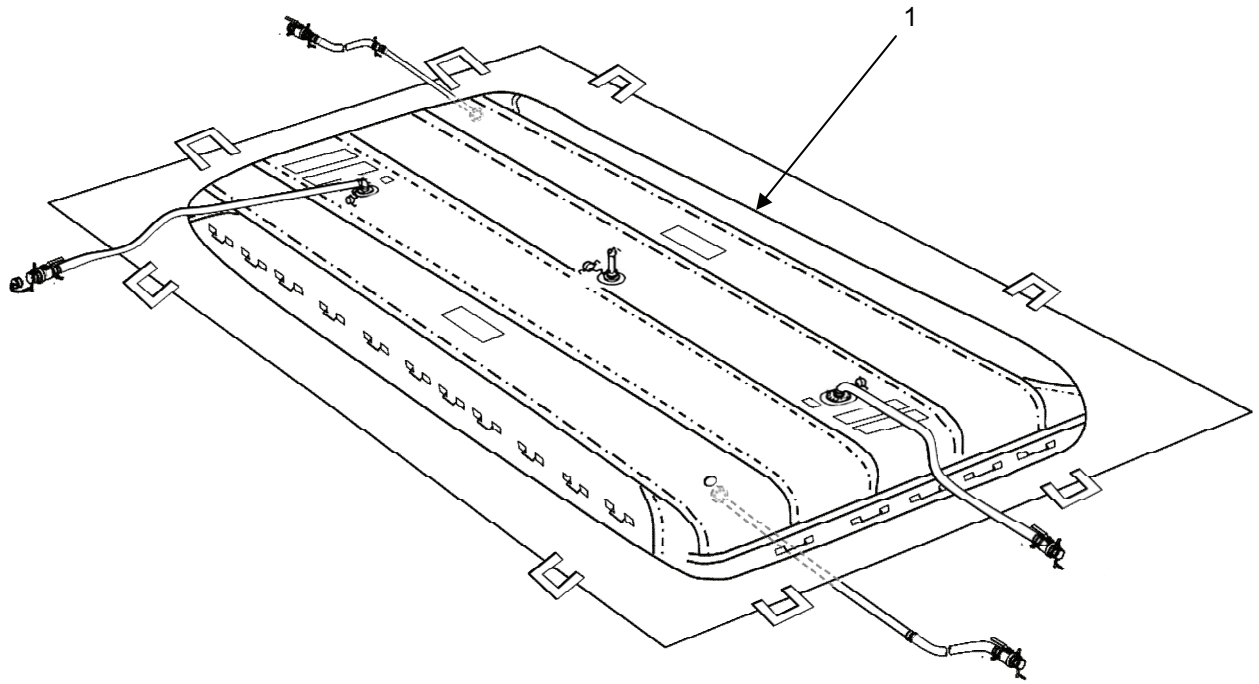

Figure 1. Tank Assembly.

(1) ITEM NO	(2) SMR CODE	(3) NSN	(4) CAGEC	(5) PART NUMBER	(6) DESCRIPTION AND USABLE ON CODE (UOC)	(7) QTY
-------------------	--------------------	------------	--------------	-----------------------	--	------------

GROUP 00

FIG. 1 TANK ASSEMBLY

1	PAFFF	5430-01-486-8208	1EMJ6	MPC-W-50K- 22636	TANK, FABRIC, COLLAPSIBLE	1
---	-------	------------------	-------	---------------------	---------------------------	---

END OF WORK PACKAGE

FIELD MAINTENANCE
TANK ENVELOPE

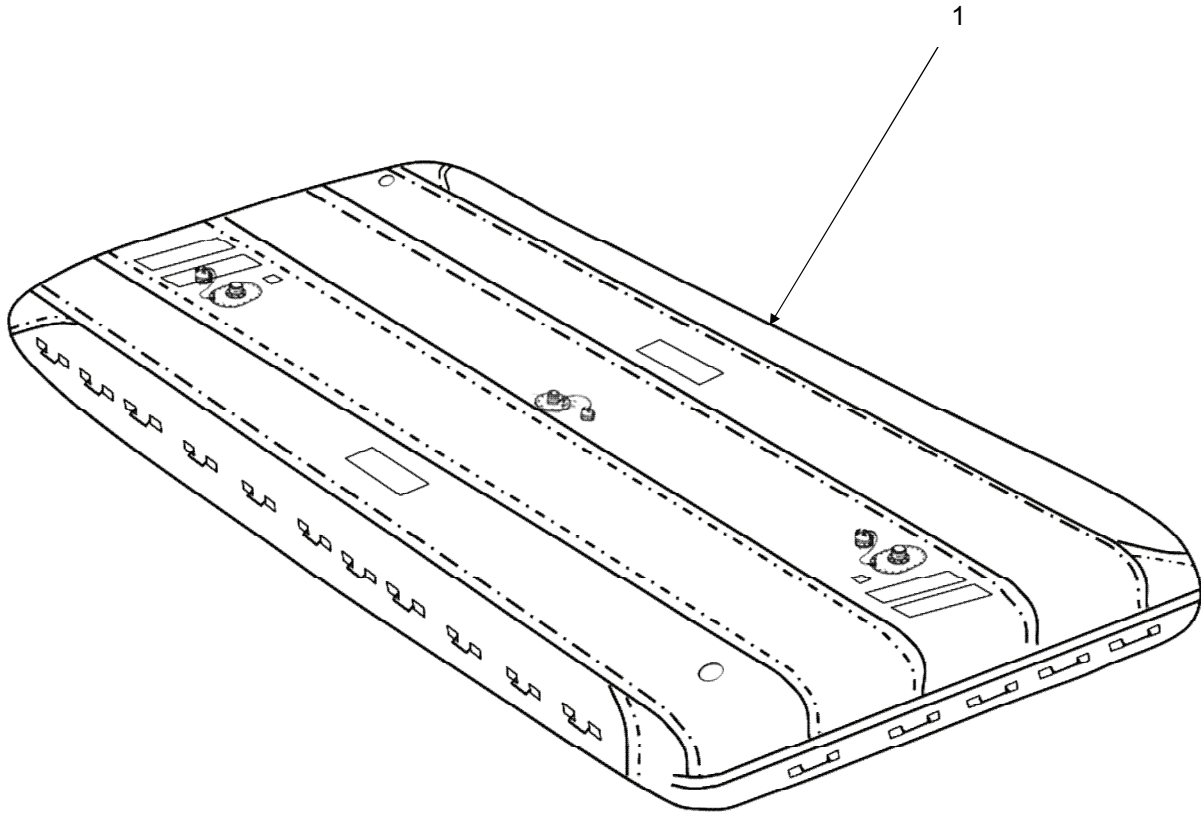

Figure 2. Tank Envelope.

(1) ITEM NO	(2) SMR CODE	(3) NSN	(4) CAGEC	(5) PART NUMBER	(6) DESCRIPTION AND USABLE ON CODE (UOC)	(7) QTY
-------------------	--------------------	------------	--------------	-----------------------	--	------------

GROUP 01

FIG. 2 TANK ENVELOPE

1	XBFZZ		1EMJ6	MPC-W-50K- 22636-RPL	TANK, FABRIC, COLLAPS, 50K GALLON WATER	1
---	-------	--	-------	-------------------------	--	---

END OF WORK PACKAGE

**FIELD MAINTENANCE
VENT FITTING ASSEMBLY**

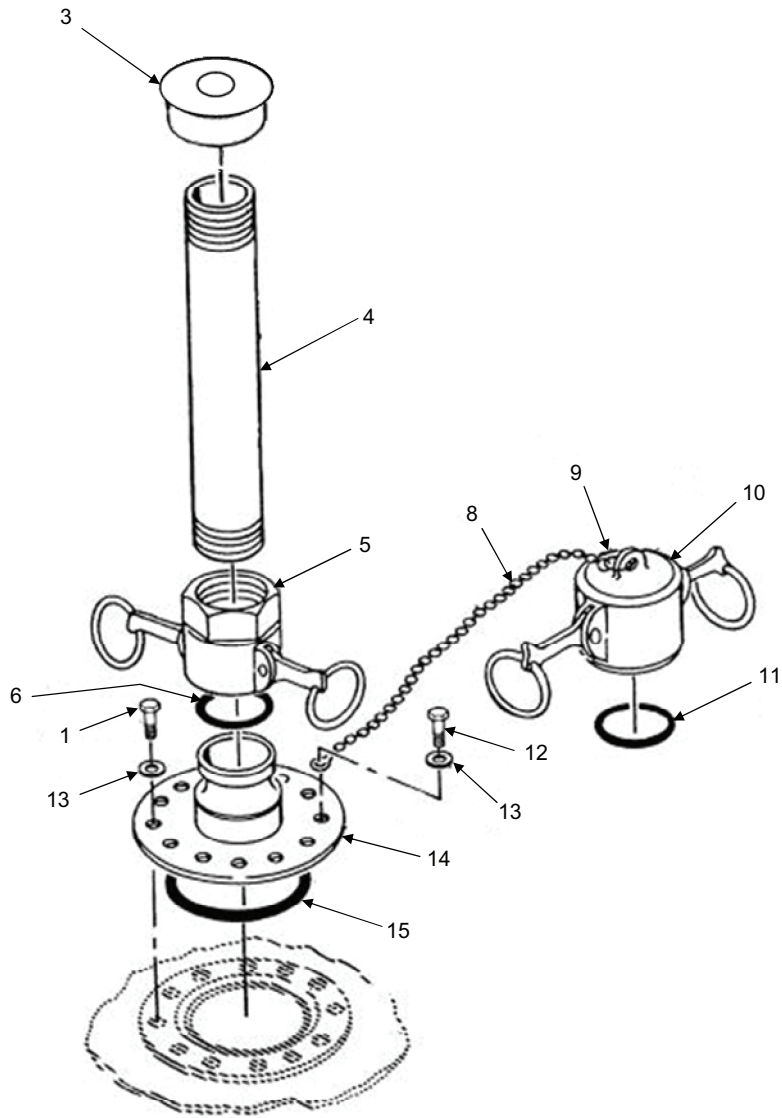

Figure 3. Vent Fitting Assembly.

(1) ITEM NO	(2) SMR CODE	(3) NSN	(4) CAGEC	(5) PART NUMBER	(6) DESCRIPTION AND USABLE ON CODE (UOC)	(7) QTY
-------------------	--------------------	------------	--------------	-----------------------	--	------------

GROUP 02

FIG. 3 VENT FITTING ASSEMBLY

1	XDFFF		1EMJ6	MPC-WV-2-B	VENT FITTING ASSEMBLY	1
2	PAFFF		1EMJ6	MPC-WV-2-D	.VENT STACK	1
3	XDFZZ		63711	MV-2	..VENT CAP, MUSHROOM	1
4	XDFZZ		63711	P-2X10-AL	..PIPE, 2 IN. (5.08 CM)	1
5	PAFZZ	4730-00-649-9103	58536	AA59326/5-6-A-1	..COUPLING HALF, QUICK DISCONNECT	1
6	PCFZZ		63711	G-CD-2-W	..GASKET	1
7	XDFFF		1EMJ6	MPC-WV-2-C	.VENT BOTTOM ASSEMBLY	1
8	MOFZZ	4010-01-526-4895	39428	3610T32	..CHAIN, WELDLESS	1
9	PAFZZ	5340-01-515-0537	39428	86805T38	..HOLDER, KEY	2
10	PAFZZ	4730-00-649-9100	58536	AA59326IX16	..CAP, QUICK DISCONNECT	1
11	PCFZZ		63711	G-CD-2-W	..GASKET	
12	PAFZZ	5305-00-068-0509	80204	B1821BH025 C125N	..SCREW, CAP, HEXAGON HEAD	8
13	PAFZZ	5310-01-232-7702	39428	98026A029	..WASHER, FLAT	8
14	PAFZZ	4730-01-416-1533	96906	MS27023-21	..COUPLING HALF, QUICK DISCONNECT	1
15	PCFZZ	5331-00-324-5262	81343	AS29513-250	..O-RING	1

END OF WORK PACKAGE

**FIELD MAINTENANCE
FILLER/DISCHARGE ASSEMBLY**

1	5	9
2 - 4	6 - 8	10 - 25

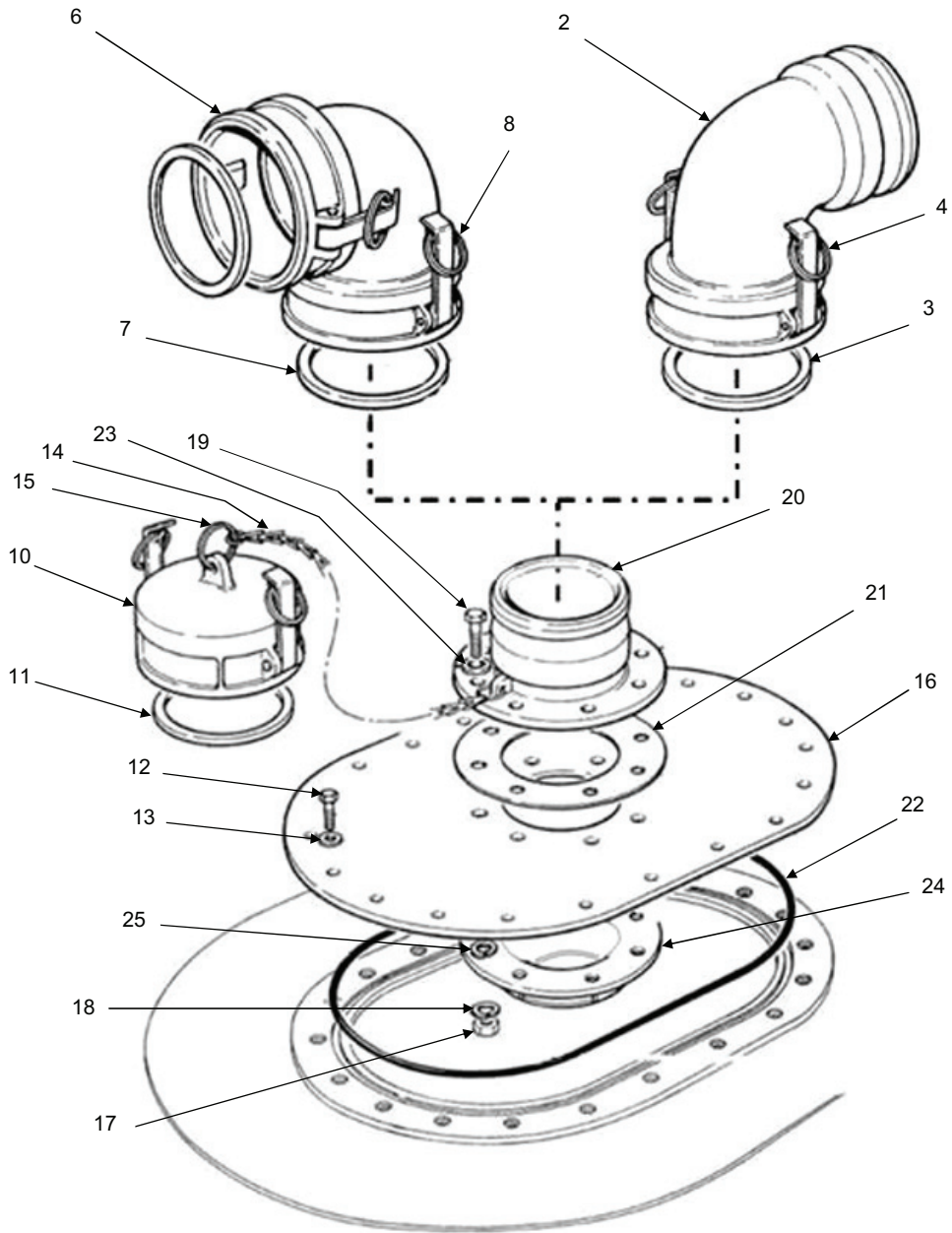

Figure 4. Filler/Discharge Assembly.

(1) ITEM NO	(2) SMR CODE	(3) NSN	(4) CAGEC	(5) PART NUMBER	(6) DESCRIPTION AND USABLE ON CODE (UOC)	(7) QTY
GROUP 06						
FIG. 4 FILLER/DISCHARGE ASSEMBLY						
1	XDFFF		1EMJ6	MPC-WE-4- MF	4 IN. (10.16 CM) X 90 DEG M/F FILLER ELBOW ASSY	1
2	XDFZZ		63711	EFM-90-4	.ELBOW, QUICK DISCONNECT, FEMALE X MALE, 4 IN. (10.16 CM)	1
3	PCFZZ		63711	G-CD-4-W	.GASKET	1
4	PAFZZ	5340-01-515-0537	39428	86805T38	.HOLDER, KEY	2
5	XDFFF		1EMJ6	MPC-WE-4- FF	4 IN. (10.16 CM) X 90 DEG F/F FILLER ELBOW ASSY	1
6	XDFZZ		63711	EFF-90-4	.ELBOW, QUICK DISCONNECT, FEMALE X FEMALE, 4 IN. (10.16 CM)	1
7	PCFZZ		63711	G-CD-4-W	.GASKET	2
8	PAFZZ	5340-01-515-0537	39428	86805T38	.HOLDER, KEY	4
9	XDFFF		1EMJ6	MPC-M-W- 1218-C	FILLER/DISCHARGE ASSEMBLY	1
10	PAFZZ	4730-00-640-6156	58536	AA59326IX-9	.CAP, QUICK DISCONNECT	1
11	PCFZZ		63711	G-CD-4-W	.GASKET	1
12	PAFZZ	5305-00-068-0509	80204	B1821BH025 C125N	.SCREW, CAP, HEXAGON HEAD	20
13	PAFZZ	5310-01-232-7702	39428	98026A029	.WASHER, FLAT	20
14	MOFZZ	4010-01-526-4895	39428	3610T32	.CHAIN, WELDLESS	1
15	PAFZZ	5340-01-515-0537	39428	86805T38	.HOLDER, KEY	4
16	XDFZZ		63711	CP-7	.PLATE, CLOSURE, COMPRESSION	1
17	PAFZZ	5310-01-519-2538	39428	93839A031	.NUT, PLAIN, HEXAGON	8
18	PAFZZ	5310-00-637-9541	05047	ASME- B18.21.1	.WASHER, LOCK	8
19	PAFZZ	5305-00-725-2317	80204	B1821BH038 C150N	.SCREW, CAP, HEXAGON HEAD	8
20	PAFZZ	4730-00-840-5347	58536	AA59326/4A- 4-A-1	.COUPLING HALF, QUICK DISCONNECT	1
21	PCFZZ		63711	G11-4-W	.GASKET	1
22	PCFZZ	5331-00-364-9862	81343	AS3578-383	.O-RING	1
23	PAFZZ	5310-01-534-7806	39428	90108A417	.WASHER, FLAT	8
24	XDFZZ		63711	SS-4-0-383	.SUCTION STUB, 4 IN. (10.16 cm)	1
25	PCFZZ	5330-00-874-3744	83259	7500-3-8	.GASKET	8
END OF FIGURE						

**FIELD MAINTENANCE
DRAIN FITTING ASSEMBLY**

1
2-8

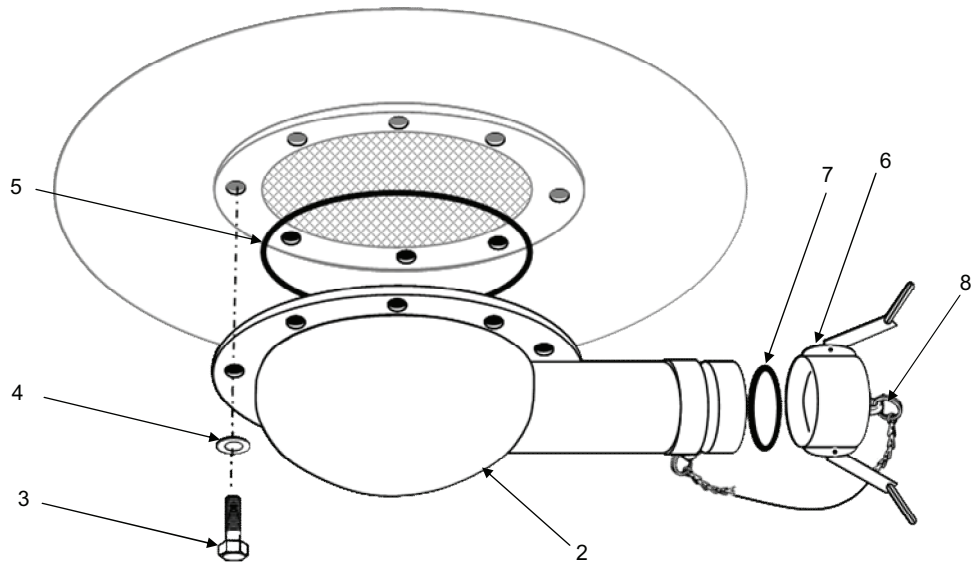

Figure 5. Drain Fitting Assembly.

(1) ITEM NO	(2) SMR CODE	(3) NSN	(4) CAGEC	(5) PART NUMBER	(6) DESCRIPTION AND USABLE ON CODE (UOC)	(7) QTY
-------------------	--------------------	------------	--------------	-----------------------	--	------------

GROUP 04

FIG. 5 DRAIN FITTING ASSEMBLY

1	XDFFF		1EMJ6	MPC-WD-2-C	DRAIN FITTING ASSEMBLY	1
2	XBFZZ		63711	DF-714X2A	.FITTING, DRAIN BOWL 90 DEG.	1
3	PAFZZ	5305-00-068-0509	80204	B1821BH025 C125N	.SCREW, CAP, HEXAGON HEAD	8
4	PAFZZ	5310-01-232-7702	39428	98026A029	.WASHER, FLAT	8
5	PCFZZ	5331-01-324-5262	81343	AS29513-250	.O-RING	1
6	PAFZZ	4730-00-649-9100	58536	AA593261X16	.CAP, DUST	1
7	PCFZZ		63711	G-CD-2-W	.GASKET, COUPLING 2 IN. (0.0508 m)	1
8	PAFZZ	5340-01-515-0537	39428	86805T38	.HOLDER, KEY	3

END OF FIGURE

**FIELD MAINTENANCE
DRAIN HOSE ASSEMBLY**

1
2-7

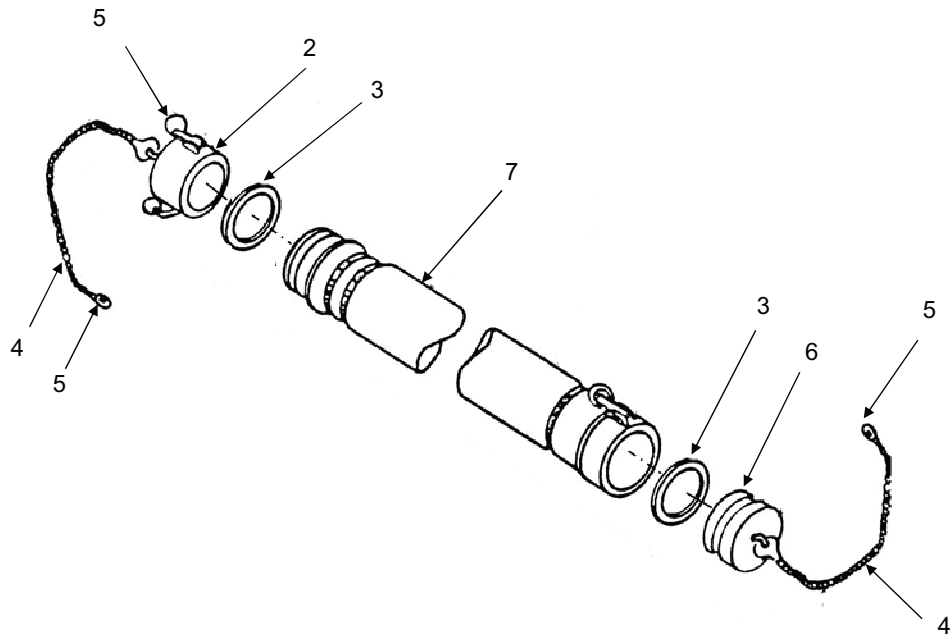

Figure 6. Drain Hose Assembly.

(1) ITEM NO	(2) SMR CODE	(3) NSN	(4) CAGEC	(5) PART NUMBER	(6) DESCRIPTION AND USABLE ON CODE (UOC)	(7) QTY
-------------------	--------------------	------------	--------------	-----------------------	--	------------

GROUP 05

FIG. 6 DRAIN HOSE ASSEMBLY

1	XDFFF		1EMJ6	MPC-WDH-2-C	HOSE ASSEMBLY, 2 IN. (5.08 CM) x 10 FT (3.05 M) WITH MALE NPT AND MALE QD	1
2	XDFZZ		63711	NA2-10-W	.HOSE, WATER, 2 IN. (5.08 CM) x 10 FT (3.05 M)	1
3	PAFZZ	4730-00-649-9100	58536	AA59326IX16	.CAP, QUICK DISCONNECT	1
4	PCFZZ		63711	G-CD-2-W	.GASKET	1
5	MOFZZ	4010-01-526-4895	39428	3610T32	.CHAIN, WELDLESS	2
6	PAFZZ	5340-01-515-0537	39428	86805T38	.HOLDER, KEY	4
7	PAFZZ	4730-00-915-5127	58536	AA59326X16	.PLUG QUICK DISCONNECT	1

END OF WORK PACKAGE

**FIELD MAINTENANCE
DRAIN BALL VALVE ASSEMBLY**

1
2-9

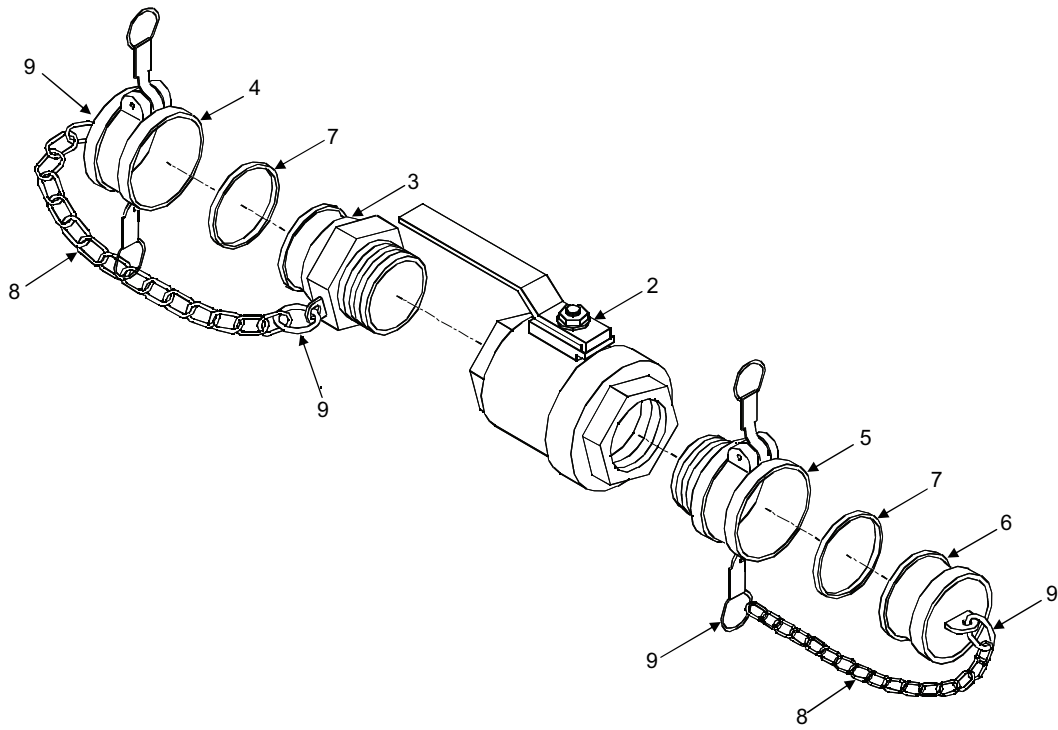

Figure 7. Drain Ball Valve Assembly.

(1) ITEM NO	(2) SMR CODE	(3) NSN	(4) CAGEC	(5) PART NUMBER	(6) DESCRIPTION AND USABLE ON CODE (UOC)	(7) QTY
GROUP 06						
FIG. 7 DRAIN BALL VALVE ASSEMBLY						
1	XDFFF		1EMJ6	MPC-WDV-2-B	BALL VALVE ASSEMBLY, 2 IN. (5.08 CM)	1
2	XDFZZ		63711	AHR-BRBV-2-W	.BALL VALVE, 2 IN. (5.08 CM)	1
3	PAFZZ	4730-00-938-7997	58536	AA59326/3A-6-A	.COUPLING HALF, QUICK DISCONNECT	1
4	PAFZZ	4730-00-649-9100	58536	AA59326IX16	.CAP, DUST, QUICK DISCONNECT	1
5	PAFZZ	4730-00-088-9285	58536	AA59326/7-6-A-1	.COUPLING HALF, QUICK DISCONNECT	2
6	PAFZZ	4730-00-915-5127	58536	AA59326X16	.PLUG, QUICK DISCONNECT	1
7	PCFZZ		63711	G-CD-2-W	.GASKET	2
8	MOFZZ	4010-01-526-4895	39428	3610T32	.CHAIN, WELDLESS	2
9	PAFZZ	5340-01-515-0537	39428	86805T38	.HOLDER, KEY	7

END OF FIGURE

**FIELD MAINTENANCE
FILLER/DISCHARGE BALL VALVE ASSEMBLY**

1
2-9

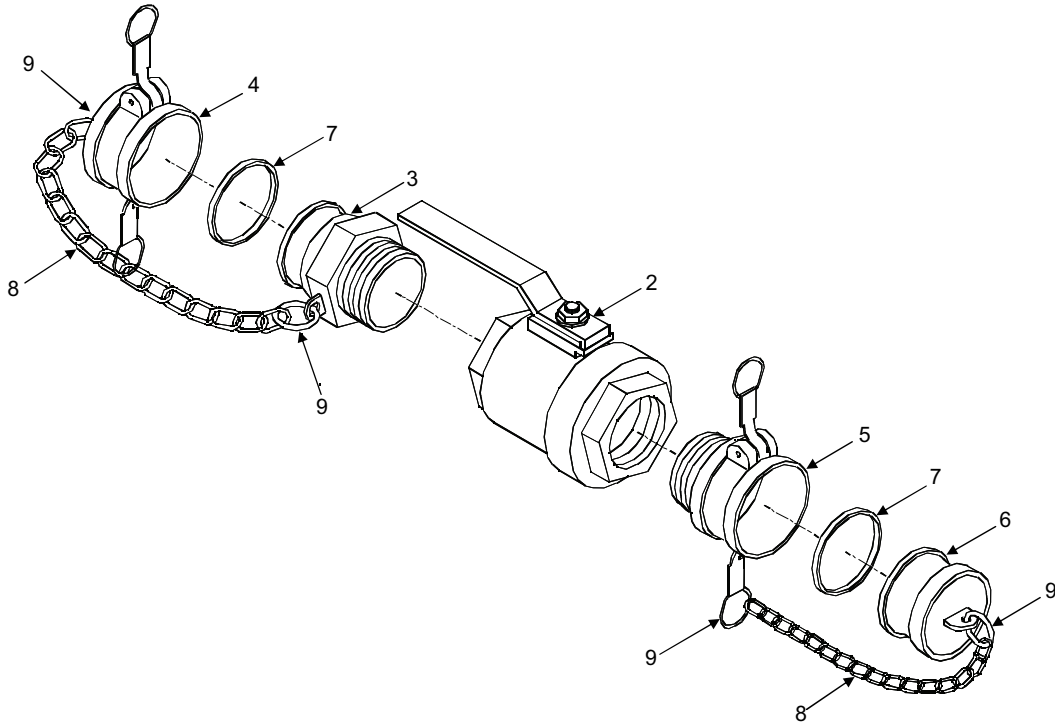

Figure 8. Filler/Discharge Ball Valve Assembly.

(1) ITEM NO	(2) SMR CODE	(3) NSN	(4) CAGEC	(5) PART NUMBER	(6) DESCRIPTION AND USABLE ON CODE (UOC)	(7) QTY
GROUP 07						
FIG. 8 FILLER/DISCHARGE BALL VALVE ASSEMBLY						
1	XDFFF		1EMJ6	MPC-WFDV- 4-B	BALL VALVE ASSEMBLY, 4 IN. (10.16 CM)	1
2	XDFZZ		63711	BV-WT-BZ-4	.BALL VALVE, 4 IN. (10.16 CM)	1
3	PAFZZ	4730-00-840-0797	58536	AA59326/3A- 9-A	.COUPLING HALF, QUICK DISCONNECT	1
4	PAFZZ	4730-00-640-6156	58536	AA59326IX-9	.CAP, QUICK DISCONNECT	1
5	PAFZZ	4730-00-649-9118	58536	AA59326VII19	.COUPLING HALF, QUICK DISCONNECT	1
6	PAFZZ	4730-00-640-6188	58536	AA59326X19	.PLUG, DUST, QUICK DISCONNECT	2
7	PCFZZ		63711	G-CD-4-W	.GASKET	2
8	MOFZZ	4010-01-526-4895	39428	3610T32	.CHAIN, WELDLESS	1
9	PAFZZ	5340-01-515-0537	39428	86805T38	.HOLDER, KEY	7

END OF FIGURE

**FIELD MAINTENANCE
FILLER/DISCHARGE HOSE ASSEMBLY**

1
2-7

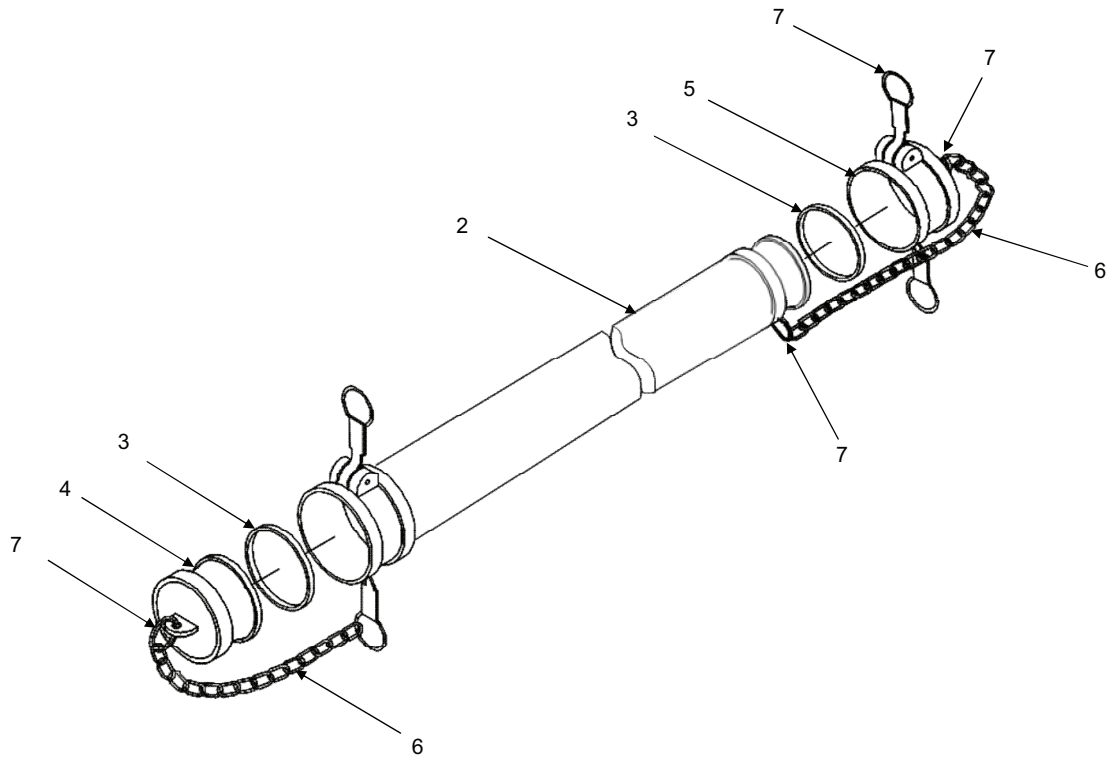

Figure 9. Filler/Discharge Hose Assembly.

(1) ITEM NO	(2) SMR CODE	(3) NSN	(4) CAGEC	(5) PART NUMBER	(6) DESCRIPTION AND USABLE ON CODE (UOC)	(7) QTY
GROUP 08						
FIG. 9 FILLER/DISCHARGE HOSE ASSEMBLY						
1	XDFFF		1EMJ6	MPC-WFDH- 4-C	HOSE ASSEMBLY, 4 IN. (10.16 CM) X 12 FT (3.66 M), TAN	1
2	PAFZZ		63711	HA4-12-W	.HOSE, 4 IN. (10.16 CM) X 12 FT (3.66 M), TAN	1
3	PCFZZ		63711	G-CD-4-W	.GASKET	2
4	PAFZZ	4730-00-640-6188	58536	AA59326X19	.PLUG, QUICK DISCONNECT	1
5	PAFZZ	4730-00-640-6156	58536	AA59326IX-9	.CAP, QUICK DISCONNECT	1
6	MOFZZ	4010-01-526-4895	39428	3610T32	.CHAIN, WELDLESS	2
7	PAFZZ	5340-01-515-0537	39428	86805T38	.HOLDER, KEY	7

END OF FIGURE

FIELD MAINTENANCE
GROUND CLOTH

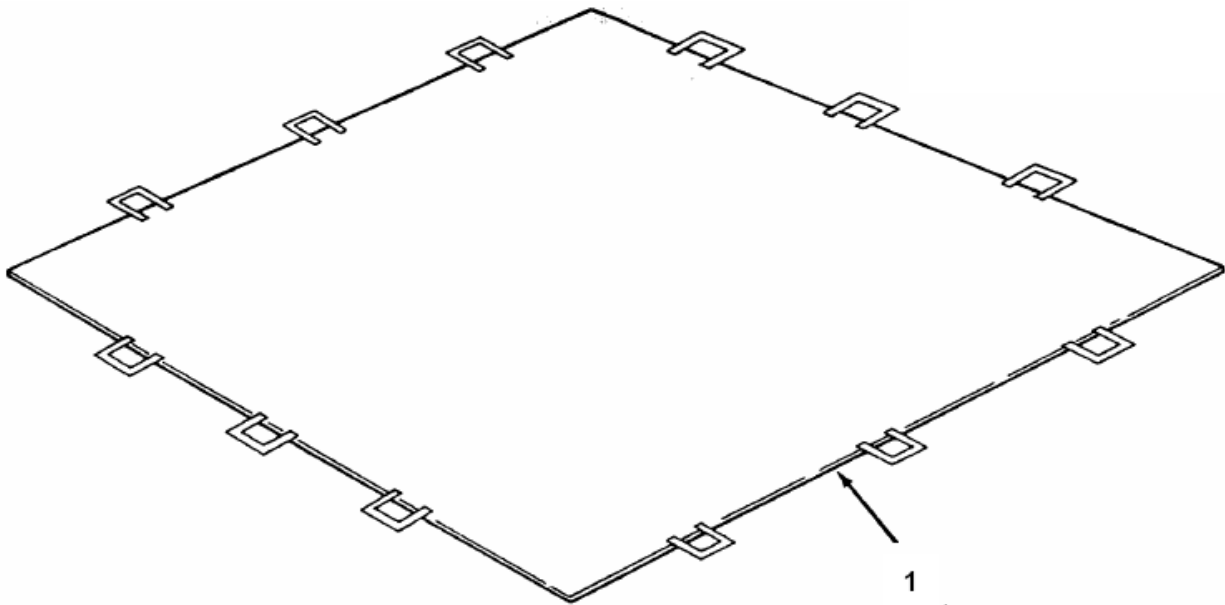

Figure 10. Ground Cloth.

(1) ITEM NO	(2) SMR CODE	(3) NSN	(4) CAGEC	(5) PART NUMBER	(6) DESCRIPTION AND USABLE ON CODE (UOC)	(7) QTY
-------------------	--------------------	------------	--------------	-----------------------	--	------------

GROUP 09 GROUND CLOTH

FIG. 10 GROUND CLOTH

1	PAFZZ		1EMJ6	MPC-W-50K- GC-3172	GROUND CLOTH, 50K TANK	1
---	-------	--	-------	-----------------------	------------------------	---

END OF WORK PACKAGE

**FIELD MAINTENANCE
REPAIR KIT, EMERGENCY**

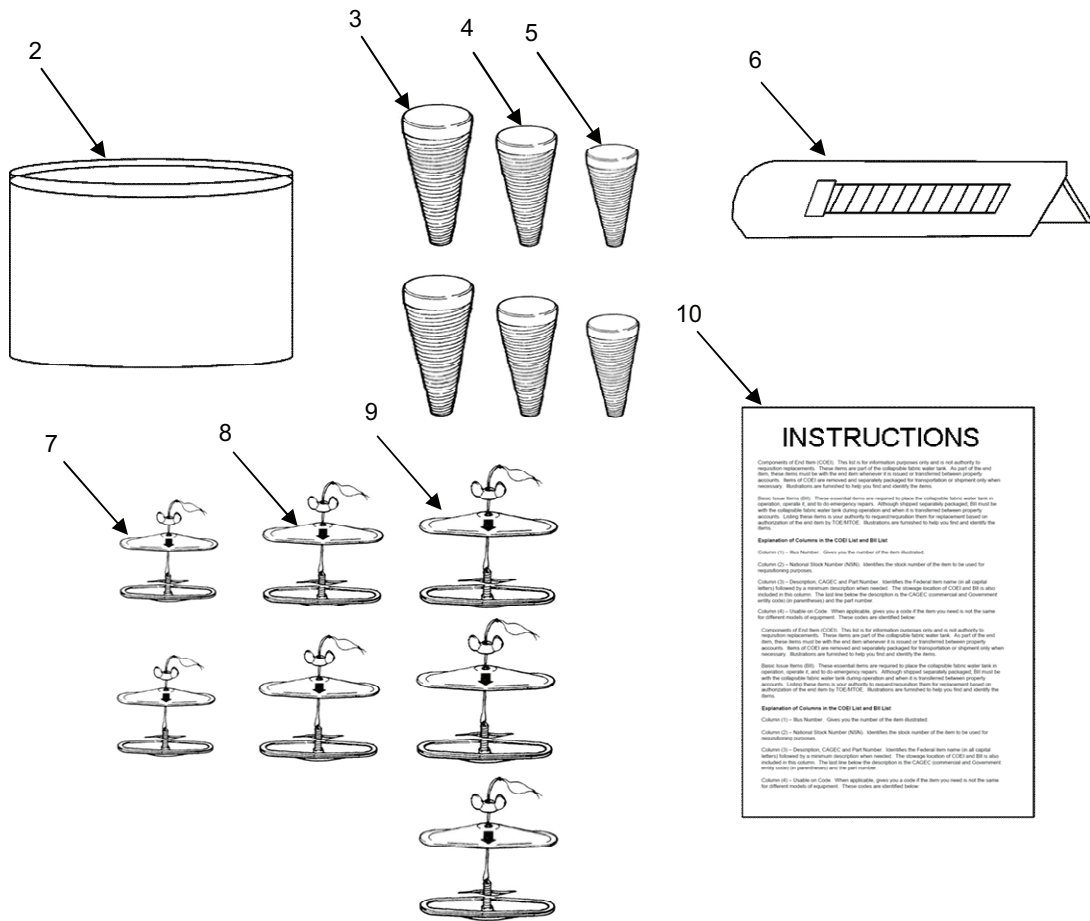

Figure 11. Emergency Repair Kit.

(1) ITEM NO	(2) SMR CODE	(3) NSN	(4) CAGEC	(5) PART NUMBER	(6) DESCRIPTION AND USABLE ON CODE (UOC)	(7) QTY
GROUP 10 EMERGENCY REPAIR ITEMS						
FIG. 11 EMERGENCY REPAIR KIT						
1	KAFFF		1EMJ6	MPC-RK-FW-3	REPAIR KIT, COLLAPSIBLE, EMERGENCY	1
2	PAFZZ		84583	2263-3-1B	.CONTAINER	1
3	PAFZZ		84583	2263-3-2	.PLUG, WOOD, 2 IN. (5.08 CM)	2
4	PAFZZ		84583	2263-3-3	.PLUG, WOOD, 1 1/2 IN. (3.81 CM)	2
5	PAFZZ		84583	2263-3-4	.PLUG, WOOD, 5/8 IN. (1.59 CM)	2
6	PAFZZ		39428	368A11	.KNIFE, UTILITY	1
7	PAFZZ	5342-00-720-8864	97403	1320E2870-1	.PATCH, MECHANICAL, FLEXIBLE SURFACE	2
8	PAFZZ	5342-00-720-8863	97403	1320E2870-2	.PATCH, MECHANICAL, FLEXIBLE SURFACE	2
9	PAFZZ	5342-00-720-8858	97403	1320E2870-3	.PATCH, MECHANICAL, FLEXIBLE SURFACE	3
10	XDFZZ		84583	2263-3-9	.INSTRUCTION SHEET, TYPE III	1
END OF WORK PACKAGE						

**FIELD MAINTENANCE
NATIONAL STOCK NUMBER INDEX**

STOCK NUMBER	FIG.	ITEM	STOCK NUMBER	FIG.	ITEM
4010-01-526-4895	3	8		5	4
	4	14	5310-01-519-2538	4	17
	6	5	5310-01-534-7806	4	23
	7	8	5330-00-874-3744	4	25
	8	8	5331-00-364-9862	4	22
	9	6	5331-01-324-5262	3	15
4730-00-088-9285	7	5		5	5
4730-00-640-6156	4	10	5340-01-515-0537	3	9
	8	4		4	4
	9	5		4	8
4730-00-640-6188	8	6		4	15
	9	4		5	8
4730-00-649-9100	3	10		6	6
	5	6		7	9
	6	3		8	9
	7	4		9	7
4730-00-649-9103	3	5	5342-00-720-8858	11	9
4730-00-649-9118	8	5	5342-00-720-8863	11	8
4730-00-840-0797	8	3	5342-00-720-8864	11	7
4730-00-840-5347	4	20	5430-01-486-8208	1	1
4730-00-915-5127	6	7			
	7	6			
4730-00-938-7997	7	3			
4730-01-416-1533	3	14			
5305-00-068-0509	3	12			
	4	12			
	5	3			
5305-00-725-2317	4	19			
5310-00-637-9541	4	18			
5310-01-232-7702	3	13			
	4	13			

**FIELD MAINTENANCE
PART NUMBER INDEX**

PART NUMBER	FIG.	ITEM	PART NUMBER	FIG.	ITEM
13202E2870-1	11	7	AA59326/3A-6-A	7	3
13202E2870-2	11	8	AA59326/3A-9-A	8	3
13202E2870-3	11	9	AA59326/4A-4-A-1	4	20
2263-3-1B	11	2	AA59326/5-6-A-1	3	5
2263-3-2	11	3	AA59326/7-6-A-1	7	5
2263-3-3	11	4	AA59326IX16	3	10
2263-3-4	11	5		5	6
2263-3-9	11	10		6	3
3610T32	3	8		7	4
	4	14	AA59326IX-9	4	10
	6	5		8	4
	7	8		9	5
	8	8	AA59326VII19	8	5
	9	6	AA59326X16	6	7
368A11	11	6		7	6
7500-3-8	4	25	AA59326X19	8	6
86805T38	3	9		9	4
	4	4	AHR-BRBV-2-W	7	2
	4	8	AS29513-250	3	15
	4	15		5	5
	5	8	AS3578-383	4	22
	6	6	ASME-B18.21.1	4	18
	7	9	B1821BH025C125N	3	12
	8	9		4	12
	9	7		5	3
90108A417	4	23	B1821BH038C150N	4	19
93839A031	4	17	BV-WT-BZ-4	8	2
98026A029	3	13	CP-7	4	16
	4	13	DF-714X2A	5	2
	5	4			

**FIELD MAINTENANCE
PART NUMBER INDEX**

PART NUMBER	FIG.	ITEM	PART NUMBER	FIG.	ITEM
EFF-90-4	4	6	MPC-W-50K-GC-3172	10	1
EFM-90-4	4	2	MPC-WD-2-C	5	1
G11-4-W	4	21	MPC-WDH-2-C	6	1
G-CD-2-W	3	6	MPC-WDV-2-B	7	1
	3	11	MPC-WE-4-MF	4	1
	5	7	MPC-WE-4-FF	4	5
	6	4	MPC-WFDH-4-C	9	1
	7	7	MPC-WFDV-4-B	8	1
G-CD-4-W	4	3	MPC-WV-2-B	3	1
	4	7	MPC-WV-2-C	3	7
	4	11	MPC-WV-2-D	3	2
	8	7	MS27023-21	3	14
	9	3	MV-2	3	3
HA4-12-W	9	2	NA2-10-W	6	2
MPC-M-W-1218-C	4	9	P-2X10-AL	3	4
MPC-RK-FW-3	11	1	SS-4-0-383	4	24
MPC-W-50K-22636	1	1			
MPC-W-50K-22636-RPL	2	1			

CHAPTER 8

SUPPORTING INFORMATION
FOR
TANK, FABRIC, COLLAPSIBLE, WATER STORAGE,
50,000 GALLON

FIELD MAINTENANCE REFERENCES

SCOPE

This work package lists all field manuals, forms, technical manuals, and miscellaneous publications referenced in this manual.

ARMY REGULATIONS

AR 200-1	Environmental Protection and Enhancement
AR 700-138	Army Logistics Readiness and Sustainability

DA PAMPHLETS

DA PAM 750-8	The Army Maintenance Management System (TAMMS) Users Manual
--------------	---

FIELD MANUALS

FM 3-3	Chemical and Biological Contamination Avoidance
FM 3-4	NBC Protection
FM 3-11.4	Multiservice Tactics, Techniques, and Procedures for Nuclear, Biological, and Chemical (NBC) Protection
FM 3-11.5	Multiservice Tactics, Techniques, and Procedures for Chemical, Biological, Radiological, and Nuclear (CBRN) Decontamination
FM 4-25.11	First Aid
FM 9-207	Operations and Maintenance of Ordnance Materiel in Cold Weather
FM 10-67-1	Concepts and Equipment of Petroleum Operations
FM 31-70	Basic Cold Weather Manual
FM 31-71	Northern Operations
FM 90-3	Desert Operations

FORMS

DA Form 2028	Recommended Changes to Publications and Blank Forms
DA Form 2404	Equipment Inspection and Maintenance Worksheet
DA Form 5988-E	Equipment Maintenance and Inspection Worksheet (Automated)
SF 361	Transportation Discrepancy Report
SF 368	Product Quality Deficiency Report

MISCELLANEOUS

ASME Y14.38-1999	The American Society of Mechanical Engineers Abbreviations and Acronyms
CTA 8-100	Common Table of Allowances, Army Medical Department Expendable/Durable Items
CTA 50-970	Common Table of Allowances, Expendable/Durable Items (Except Medical, Class V Repair Parts, and Heraldic Items)

SUPPLY CATALOGS

SC 4910-95-A81	Standard Automotive Tool Set (SATS)
SC 5180-95-N26	Tool Kit, General Mechanic's Automotive

TECHNICAL BULLETINS

TB MED 577 Sanitary Controls and Surveillance of Filled Water Supplies

TECHNICAL MANUALS

TM 10-4610-234-13 Operator's Unit and Direct Support Maintenance Manual for 40,000 Gallon Water Storage and Distribution System

TM 750-244-6 Procedures for Destruction of Tank-Automotive Equipment to Prevent Enemy Use

END OF WORK PACKAGE

**FIELD MAINTENANCE
MAINTENANCE ALLOCATION CHART (MAC) INTRODUCTION**

The Army Maintenance System MAC

This introduction provides a general explanation of all maintenance and repair functions authorized at the two maintenance levels under the Two-Level Maintenance System concept.

This MAC (immediately following the introduction) designates overall authority and responsibility for the performance of maintenance functions on the identified end item or component. The application of the maintenance functions to the end item or component shall be consistent with the capacities and capabilities of the designated maintenance levels, which are shown on the MAC in column (4) as:

Field – includes two subcolumns, Crew (C) and Maintainer (F).

Sustainment – includes two subcolumns, Below Depot (H) and Depot (D).

The maintenance to be performed at field and sustainment levels is described as follows:

1. Crew maintenance. The responsibility of a using organization to perform maintenance on its assigned equipment. It normally consists of inspecting, servicing, lubricating, adjusting, and replacing parts, minor assemblies, and subassemblies. The replace function for this level of maintenance is indicated by the letter “C” in the third position of the SMR code. A “C” appearing in the fourth position of the SMR code indicates complete repair is possible at the crew maintenance level.
2. Maintainer maintenance. Maintenance accomplished on a component, accessory, assembly, subassembly, plug-in unit, or other portion either on the system or after it is removed. The replace function for this level of maintenance is indicated by the letter “F” appearing in the third position of the SMR code. An “F” appearing in the fourth position of the SMR code indicates complete repair is possible at the field maintenance level. Items are returned to the user after maintenance is performed at this level.
3. Below depot sustainment. Maintenance accomplished on a component, accessory, assembly, subassembly, plug-in unit, or other portion either on the system or after it is removed. The replace function for this level of maintenance is indicated by the letter “H” appearing in the third position of the SMR code. An “H” appearing in the fourth position of the SMR code indicates complete repair is possible at the below depot sustainment maintenance level. Items are returned to the supply system after maintenance is performed at this level.
4. Depot sustainment. Maintenance accomplished on a component, accessory, assembly, subassembly, plug-in unit, or other portion either on the system or after it is removed. The replace function for this level of maintenance is indicated by the letter “D” or “K” appearing in the third position of the SMR code. Depot sustainment maintenance can be performed by either depot personnel or contractor personnel. A “D” or “K” appearing in the fourth position of the SMR code indicates complete repair is possible at the depot sustainment maintenance level. Items are returned to the supply systems after maintenance is performed at this level.

The tools and test equipment requirements table (immediately following the MAC) lists the tools and test equipment (both special tools and common tool sets) required for each maintenance function as referenced from the MAC.

The remarks table (immediately following the tools and test equipment requirements) contains supplemental instructions and explanatory notes for a particular maintenance function.

MAINTENANCE FUNCTIONS

Maintenance functions are limited to and defined as follows:

1. **Inspect.** To determine the serviceability of an item by comparing its physical, mechanical, and/or electrical characteristics with established standards through examination (e.g., by sight, sound, or feel). This includes scheduled inspection and gauging and evaluation of cannon tubes.
2. **Test.** To verify serviceability by measuring the mechanical, pneumatic, hydraulic, or electrical characteristics of an item and comparing those characteristics with prescribed standards on a scheduled basis, i.e., load testing of lift devices and hydrostatic testing of pressure hoses.
3. **Service.** Operations required periodically to keep an item in proper operating condition; e.g., to clean (includes decontaminate, when required), to preserve, to drain, to paint, or to replenish fuel, lubricants, chemical fluids, or gases. This includes scheduled exercising and purging of recoil mechanisms. The following are examples of service functions:
 - a. **Unpack.** To remove from packing box for service or when required for the performance of maintenance operations.
 - b. **Repack.** To return item to packing box after service and other maintenance operations.
 - c. **Clean.** To rid the item of contamination.
 - d. **Touch up.** To spot paint scratched or blistered surfaces.
 - e. **Mark.** To restore obliterated identification.
4. **Adjust.** To maintain or regulate, within prescribed limits, by bringing into proper position, or by setting the operating characteristics to specified parameters.
5. **Align.** To adjust specified variable elements of an item to bring about optimum or desired performance.
6. **Calibrate.** To determine and cause corrections to be made or to be adjusted on instruments of test, measuring, and diagnostic equipment used in precision measurement. Consists of comparisons of two instruments, one of which is a certified standard of known accuracy, to detect and adjust any discrepancy in the accuracy of the instrument being compared.
7. **Remove/Install.** To remove and install the same item when required to perform service or other maintenance functions. Install may be the act of emplacing, seating, or fixing into position a spare, repair part, or module (component or assembly) in a manner to allow the proper functioning of an equipment or system.
8. **Paint (ammunition only).** To prepare and spray color coats of paint so that the ammunition can be identified and protected. The color indicating primary use is applied, preferably, to the entire exterior surface as the background color of the item. Other markings are to be repainted as original so as to retain proper ammunition identification.
9. **Replace.** To remove an unserviceable item and install a serviceable counterpart in its place. "Replace" is authorized by the MAC and assigned maintenance level is shown as the third position code of the Source, Maintenance and Recoverability (SMR) code.
10. **Repair.** The application of the maintenance services, including fault location/troubleshooting, removal/installation, disassembly/assembly procedures, and maintenance actions to identify troubles and restore serviceability to an item by correcting specific damage, fault, malfunction, or failure in a part, subassembly, module (component or assembly), end item, or system.

MAINTENANCE FUNCTIONS – CONTINUED**NOTE**

The following definitions are applicable to the “repair” maintenance function:

Services. Inspect, test, service, adjust, align, calibrate, and/or replace.

Fault location/troubleshooting. The process of investigating and detecting the cause of equipment malfunctioning; the act of isolating a fault within a system or Unit Under Test (UUT).

Disassembly/assembly. The step-by-step breakdown (taking apart) of a spare/functional group coded item to the level of its least component, that is assigned an SMR code for the level of maintenance under consideration (i.e., identified as maintenance significant).

Actions. Welding, grinding, riveting, straightening, facing, machining, and/or resurfacing.

11. Overhaul. That maintenance effort (service/action) prescribed to restore an item to a completely serviceable/operational condition as required by maintenance standards in appropriate technical publications. Overhaul is normally the highest degree of maintenance performed by the Army. Overhaul does not normally return an item to like new condition.
12. Rebuild. Consists of those services/actions necessary for the restoration of unserviceable equipment to a like new condition in accordance with original manufacturing standards. Rebuild is the highest degree of material maintenance applied to Army equipment. The rebuild operation includes the act of returning to zero those age measurements (e.g., hours/miles) considered in classifying Army equipment/components.

Explanation of Columns in the MAC

Column (1) Group Number. Column (1) lists Functional Group Code (FGC) numbers, the purpose of which is to identify maintenance significant components, assemblies, subassemblies, and modules with the Next Higher Assembly (NHA).

Column (2) Component/Assembly. Column (2) contains the item names of components, assemblies, subassemblies, and modules for which maintenance is authorized.

Column (3) Maintenance Function. Column (3) lists the functions to be performed on the item listed in column (2). (For a detailed explanation of these functions refer to “Maintenance Functions” outlined above).

Column (4) Maintenance Level. Column (4) specifies each level of maintenance authorized to perform each function listed in column (3), by indicating work time required (expressed as manhours in whole hours or decimals) in the appropriate subcolumn. This work time figure represents the active time required to perform that maintenance function at the indicated level of maintenance. If the number or complexity of the tasks within the listed maintenance function varies at different maintenance levels, appropriate work time figures are to be shown for each level. The work time figure represents the average time required to restore an item (assembly, subassembly, component, module, end item, or system) to a serviceable condition under typical field operating conditions. This time includes preparation time (including any necessary disassembly/assembly time), troubleshooting/fault location time, and quality assurance time in addition to the time required to perform the specific tasks identified for the maintenance functions authorized in the MAC.

MAINTENANCE FUNCTIONS – CONTINUED

The symbol designations for the various maintenance levels are as follows:

Field:

- C Crew maintenance
- F Maintainer maintenance

Sustainment:

- L Specialized Repair Activity (SRA)
- H Below depot maintenance
- D Depot maintenance

NOTE

The “L” maintenance level is not included in column (4) of the MAC. Functions to this level of maintenance are identified by work time figure in the “H” column of column (4), and an associated reference code is used in the REMARKS column (6). This code is keyed to the remarks and the SRA complete repair application is explained there.

Column (5) Tools and Equipment Reference Code. Column (5) specifies, by code, those common tool sets (not individual tools), common Test, Measurement and Diagnostic Equipment (TMDE), and special tools, special TMDE, and special support equipment required to perform the designated function. Codes are keyed to the entries in the tools and test equipment table.

Column (6) Remarks Code. When applicable, this column contains a letter code, in alphabetical order, which is keyed to the remarks table entries.

Explanation of Columns in the Tools and Test Equipment Requirements

Column (1) – Tool or Test Equipment Reference Code. The tool or test equipment reference code correlates with a code used in Column (5) of the MAC.

Column (2) – Maintenance Level. The lowest level of maintenance authorized to use the tool or test equipment.

Column (3) – Nomenclature. Name or identification of the tool or test equipment.

Column (4) – National Stock Number (NSN). The NSN of the tool or test equipment.

Column (5) – Tool Number. The manufacturer’s part number.

Explanation of the Columns in the Remarks

Column (1) – Remarks Code. The code recorded in column (6) of the MAC.

Column (2) – Remarks. This column lists information pertinent to the maintenance function being performed as indicated in the MAC.

END OF WORK PACKAGE

**OPERATOR AND FIELD MAINTENANCE
MAINTENANCE ALLOCATION CHART (MAC)**

MAINTENANCE ALLOCATION CHART (MAC)

Table 1. Maintenance Allocation Chart (MAC).

(1) GROUP NUMBER	(2) COMPONENT/ ASSEMBLY	(3) MAINTENANCE FUNCTION	(4) MAINTENANCE LEVEL				(5) TOOLS AND EQUIPMENT REFERENCE CODE	(6) REMARKS CODE
			FIELD		SUSTAINMENT			
			CREW	MAINTAINER	BELOW DEPOT	DEPOT		
			C	F	H	D		
00	TANK ASSEMBLY	Inspect	0.7	0.7			1	A
		Service		2.5				
		Replace		4.0				
01	TANK ENVELOPE	Inspect	0.2	0.2			1,2	A C
		Repair	0.5	0.5				
02	VENT FITTING ASSEMBLY	Inspect	0.2	0.2			1,2	A
		Service		0.5				
		Repair	0.2	1.0				
03	FILLER/DISCHARGE ASSEMBLY	Inspect	0.2	0.2			1,2	A
		Replace		0.7				
		Repair	0.2	0.1				
04	DRAIN FITTING ASSEMBLY	Inspect	0.2	0.2			1,2,3	A
		Replace		0.2				
		Repair	0.1	0.5				
05	DRAIN HOSE ASSEMBLY	Inspect	0.2	0.2			1	B
		Service		0.2				
		Repair	0.1	0.5				
06	DRAIN BALL VALVE ASSEMBLY	Inspect	0.2	0.2			1	A
		Service		0.2				
		Replace		0.2				
		Repair	0.1	0.5				
07	FILLER DISCHARGE BALL VALVE ASSEMBLY	Inspect	0.2	0.2			1	A
		Service		0.2				
		Replace		0.2				
		Repair	0.1	1.0				
08	FILLER/DISCHARGE HOSE ASSEMBLY	Inspect	0.2	0.2			1	A
		Service		0.2				
		Repair	0.1	0.5				
09	GROUND CLOTH	Inspect	0.1	0.1			1	B
		Replace	0.5	0.5				
10	EMERGENCY REPAIR KIT	Inspect	0.1	0.1				
		Replace	0.5					

MAINTENANCE ALLOCATION CHART (MAC) – CONTINUED
Table 2. Tools and Test Equipment for Water Tank Assembly.

TOOL OR TEST EQUIPMENT	MAINTENANCE LEVEL	NOMENCLATURE	NATIONAL STOCK NUMBER	TOOL NUMBER
1	F	Tool kit, general mechanic's	5180-00-177-7033	SC 5180-90-N26
2	F	Wrench, torque 0-175 ft lb	5120-00-396-5937	B107.14
3	F	Adapter, socket wrench, 3/8 in. female square end 1/2 in. male square end	5120-01-240-8703	B107.10M

Table 3. Remarks for Water Tank Assembly.

REMARK CODE	REMARKS
A	Operator inspection occurs with assembly intact. Field level inspection occurs after the assembly has been disassembled and cleaned.
B	Operator repair is limited to replacement of gaskets on quick disconnect couplings.
C	Operator repair is limited to use of the clamps and plugs included with the emergency repair kit.

END OF WORK PACKAGE

**FIELD MAINTENANCE
COMPONENTS OF END ITEM (COEI) AND BASIC ISSUE ITEMS (BII) LISTS**

INTRODUCTION**SCOPE**

This work package lists the COEI and BII for the Tank Assembly to aid in inventorying items for safe and efficient operation of the equipment.

GENERAL

The COEI and BII information is divided into the following lists:

Components of End Item (COEI). This list is for informational purposes only and is not authority to requisition replacements. These items are part of the Tank Assembly. As part of the end item, these items must be with the end item whenever it is issued or transferred between property accounts. Items of COEI are removed and separately packaged for transportation or shipment only when necessary. Illustrations are furnished to help you find and identify the items.

Basic Issue Items (BII). These essential items are required to place a Tank Assembly in operation, to operate it, and to do emergency repairs. Although shipped separately packaged, BII must be with the Tank Envelope during operation and when it is transferred between property accounts. Listing these items is your authority to request/requisition them for replacement based on authorization of the end item by TOE/MTOE. Illustrations are furnished to help find and identify the items.

Explanation of Columns in the COEI List and the BII List

Column (1) Illus Number. Gives you the number of the item illustrated.

Column (2) National Stock Number (NSN). Identifies the stock number of the item to be used for requisitioning purposes.

Column (3) Description, Part Number/(CAGEC). Identifies the Federal item name (in all capital letters) followed by a minimum description when needed. The stowage location of COEI and BII is also included in this column. The last line below the description is the part number and the Commercial and Government Entity Code (CAGEC) (in parentheses).

Column (4) Usable On Code. When applicable, gives you a code if the item you need is not the same for different models of equipment.

Column (5) U/I. Unit of Issue (U/I) indicates the physical measurement or count of the item as issued per the National Stock Number shown in column (2).

Column (6) Qty Rqr. Indicates the quantity required.

COMPONENTS OF END ITEM (COEI) AND BASIC ISSUE ITEMS (BII) LISTS

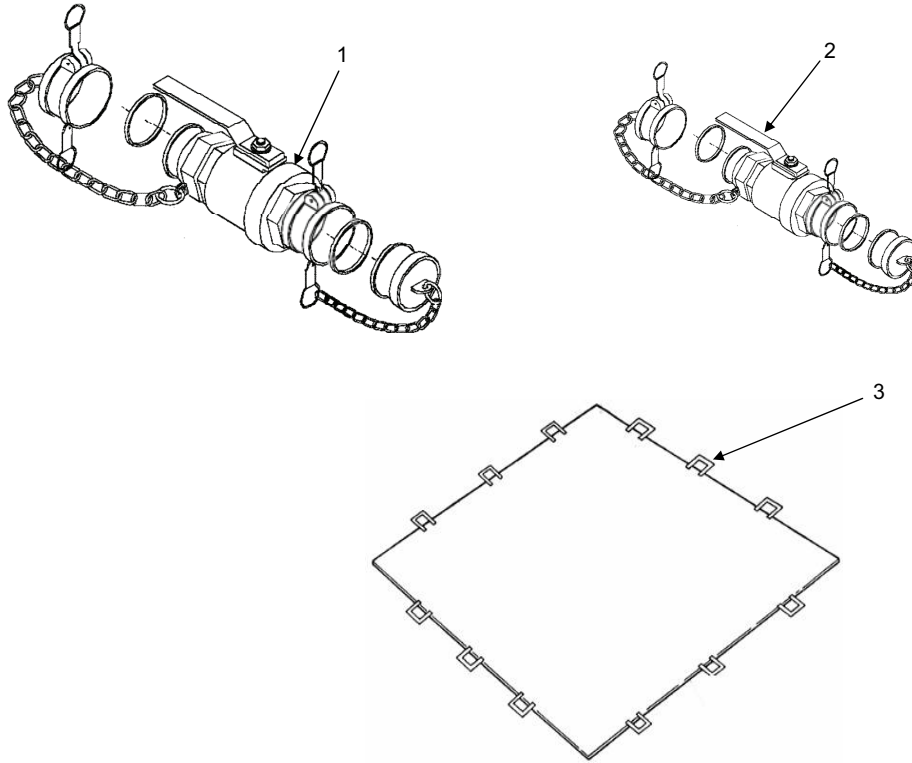

Table 1. Components of End Item (COEI) List.

(1) ILLUS NUMBER	(2) NATIONAL STOCK NUMBER (NSN)	(3) DESCRIPTION, PART NUMBER/(CAGEC)	(4) USABLE ON CODE	(5) U/I	(6) QTY RQR
1		Ball Valve Assembly, Filler/Discharge, 4 in. (10.16 cm) MPC-WFDV-4-B (1EMJ6)		EA	2
2		Ball Valve Assembly, Drain, 2 in. (5.08 cm) MPC-WDV-2-B (1EMJ6)		EA	2
3		Ground Cloth, 50K Tank, Water MPC-W-50K-GC-3131 (1EMJ6)		EA	1

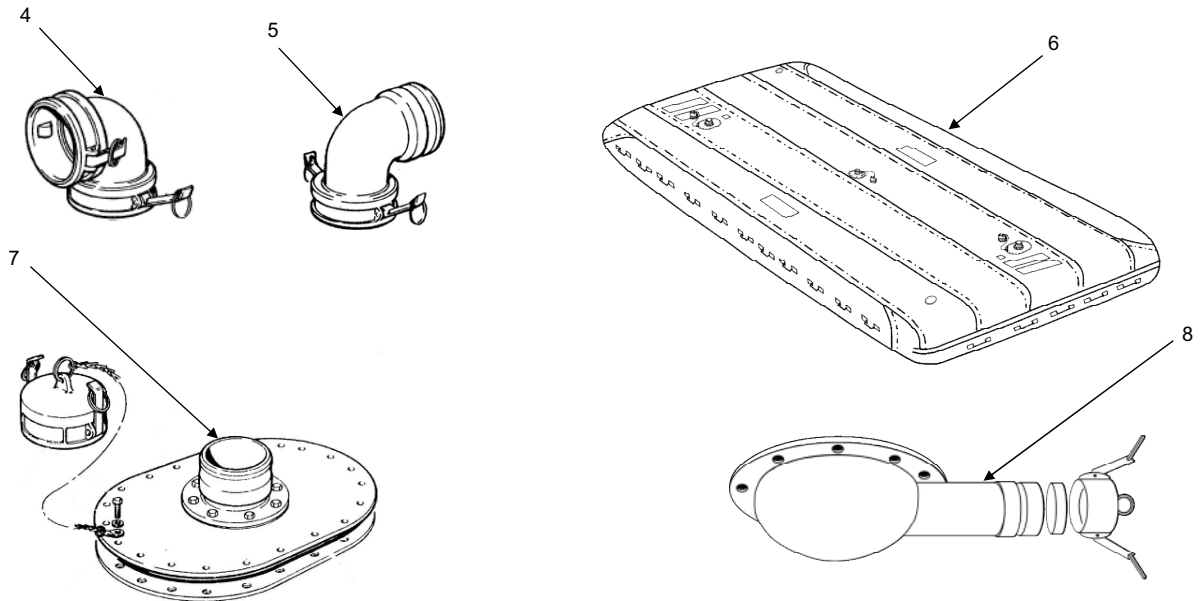

Table 1. Components of End Item (COEI) List – Continued.

(1) ILLUS NUMBER	(2) NATIONAL STOCK NUMBER (NSN)	(3) DESCRIPTION, PART NUMBER/(CAGEC)	(4) USABLE ON CODE	(5) U/I	(6) QTY RQR
4		Elbow, Quick Disconnect, Female x Female, 4-in. (10.16 cm) EFF-90-4 (63711)		EA	1
5		Elbow, Quick Disconnect, Female x Male, 4-in. (10.16 cm) EFM-90-4 (63711)		EA	1
6		Tank, Fabric, Collapsible, 50K, MPC-50KW-22276-RPL (1EMJ6)		EA	1
7		Filler/Discharge Assembly, 4 in. (10.16 cm) MPC-M-W-1218-B (1EMJ6)		EA	2
8		Fitting Assembly, Tank Drain MPC-WD-2-B (1EMJ6)		EA	2

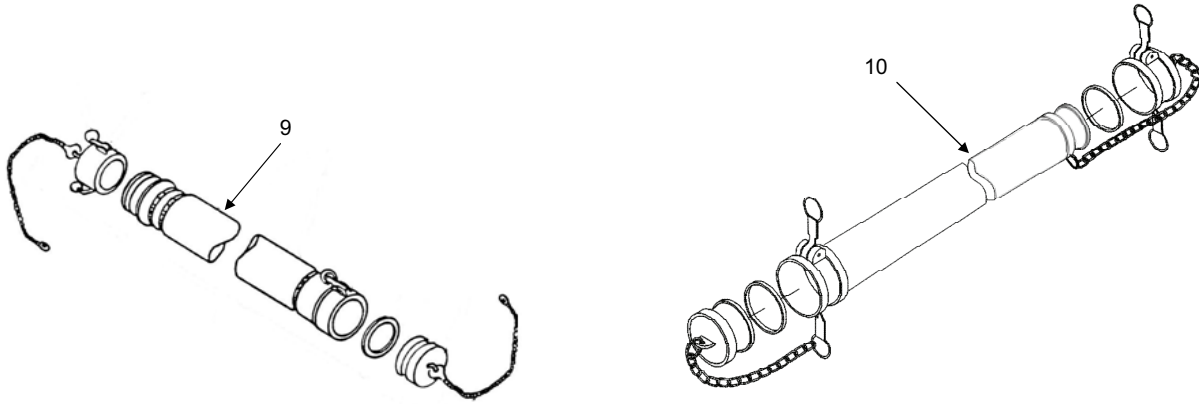

Table 1. Components of End Item (COEI) List – Continued.

(1) ILLUS NUMBER	(2) NATIONAL STOCK NUMBER (NSN)	(3) DESCRIPTION, PART NUMBER/(CAGEC)	(4) USABLE ON CODE	(5) U/I	(6) QTY RQR
9		Hose Assembly, Filler/Discharge, 4 in. (10.16 cm) x 12 ft (3.66 m) MPC-WFDH-4-C (1DFDO)		EA	2
10		Hose Assembly, Tank Drain, 2-in. (5.08 cm) x 10-ft (3.05 m) MPC-WDH-2-C (1EMJ6)		EA	2

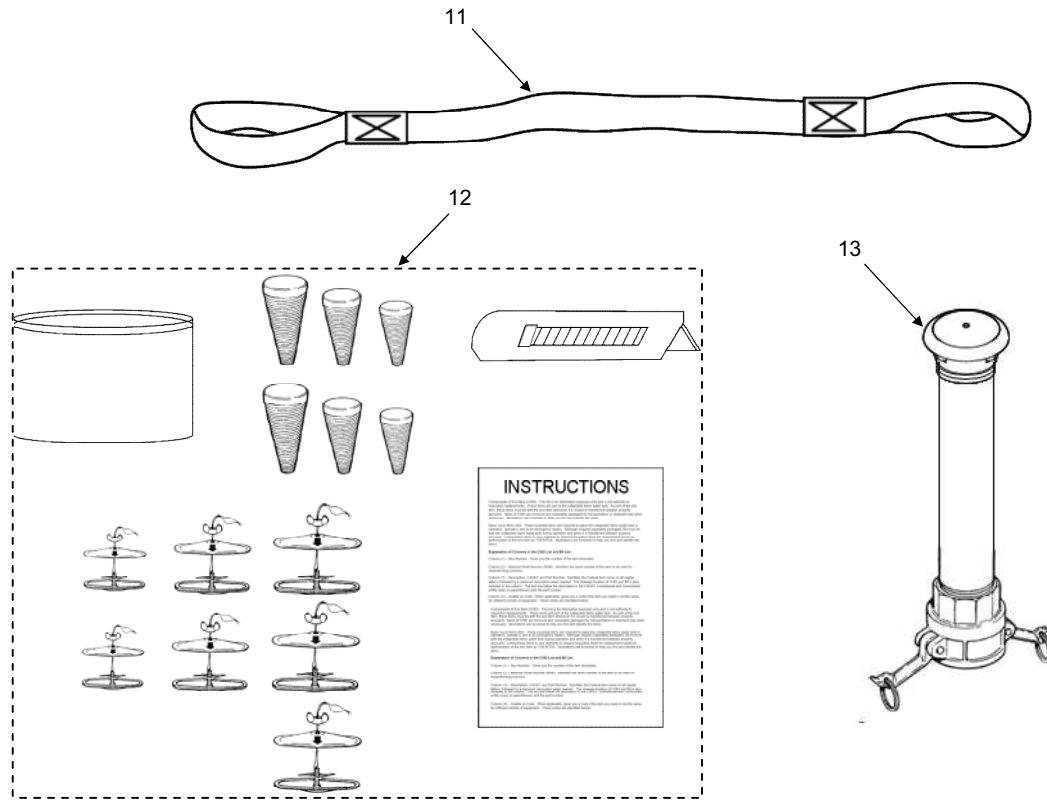

Table 1. Components of End Item (COEI) List – Continued.

(1) ILLUS NUMBER	(2) NATIONAL STOCK NUMBER (NSN)	(3) DESCRIPTION, PART NUMBER/(CAGEC)	(4) USABLE ON CODE	(5) U/I	(6) QTY RQR
11		Lifting Sling, 2-in. (5.08 cm) x 15-ft (4.57 m) 011092 (1EMJ6)		EA	2
12		Repair Kit, Collapsible, Emergency, Type III MPC-RK-102-W-A (1EMJ6)		EA	1
13		Vent Fitting Assembly MPC-WV-50K-2-B-W (1EMJ6)		EA	1

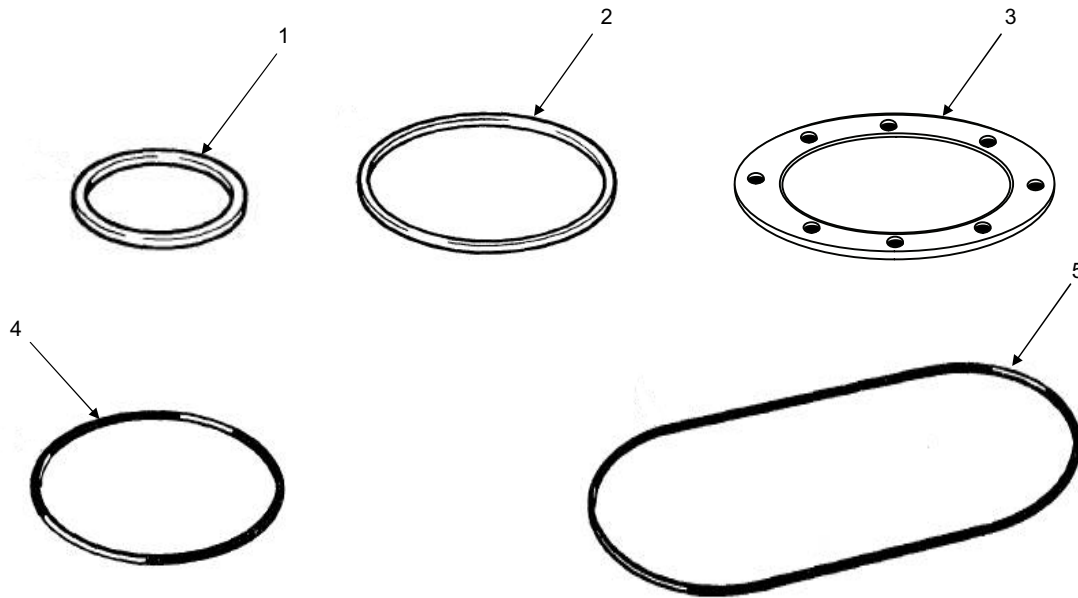

Table 2. On Board Spares.

(1) ILLUS NUMBER	(2) NATIONAL STOCK NUMBER (NSN)	(3) DESCRIPTION, PART NUMBER/(CAGEC)	(4) USABLE ON CODE	(5) U/I	(6) QTY RQR
1	5330-00-612-2414	Gasket G-CD-4-W (63711)			1
2	5330-00-899-4509	Gasket G-CD-2-W (63711)			1
3	5330-01-262-5120	Gasket G11-4-W (63711)			2
4	5330-00-324-5262	O-Ring AS29513-250 (81343)			3
5	5330-00-364-9862	O-Ring AS3578-383 (81343)			2



Table 3. Basic Issue Items (BII).

(1) ILLUS NUMBER	(2) NATIONAL STOCK NUMBER (NSN)	(3) DESCRIPTION, PART NUMBER/(CAGEC)	(4) USABLE ON CODE	(5) U/I	(6) QTY RQR
1		Technical Manual, Operator and Unit Maintenance Including Repair Parts and Special Tools List TM 10-5430-258-13&P		EA	1

END OF WORK PACKAGE

**FIELD MAINTENANCE
ADDITIONAL AUTHORIZATION LIST (AAL)**

INTRODUCTION

SCOPE

This work package lists additional items you are authorized for the support of the Water Tank Assembly.

GENERAL

This list identifies items that do not have to accompany the Water Tank Assembly and that do not have to be turned in with it. These items are all authorized to you by Common Table of Allowances (CTA), Modified Table of Organization and Equipment (MTOE), Table of Distribution and Allowances (TDA), or Joint Table of Allowances (JTA).

Explanations of Columns in the AAL

Column (1) National Stock Number (NSN). Identifies the stock number of the item to be used for requisitioning purposes.

Column (2) Description, Part Number/(CAGEC). Identifies the Federal item name (in all capital letters) followed by a minimum description when needed. The last line below the description is the part number and the Commercial and Government Entity Code (CAGEC) (in parentheses).

Column (3) Usable On Code. When applicable, gives you a code if the item you need is not the same for different models of equipment.

Column (4) U/I. Unit of Issue (U/I) indicates the physical measurement or count of the item as issued per the National Stock Number shown in column (1).

Column (5) Qty Recm. Indicates the quantity recommended.

Table 1. Additional Authorization List (AAL).

(1) NATIONAL STOCK NUMBER	(2) DESCRIPTION, PART NUMBER/(CAGEC)	(3) USABLE ON CODE	(4) U/I	(5) QTY RECM
MTOE AND CTA AUTHORIZED ITEMS NOT APPLICABLE TO THIS EQUIPMENT.				

END OF WORK PACKAGE

**FIELD AND SUSTAINMENT MAINTENANCE
EXPENDABLE AND DURABLE ITEMS LIST (EDIL)**

INTRODUCTION

SCOPE

This work package lists expendable and durable items that you will need to operate and maintain the Water Tank Assembly. This list is for information only and is not authority to requisition the listed items. These items are authorized to you by CTA 50-970, Expendable/Durable Items (Except Medical, Class V Repair Parts, and Heraldic Items), CTA 50-909, Field and Garrison Furnishings and Equipment or CTA 8-100, Army Medical Department Expendable/Durable Items.

Explanation of Columns in the Expendable and Durable Items List

Column (1) Item No. This number is assigned to the entry in the list and is referenced in the narrative instructions to identify the item (e.g., Use brake fluid (WP 0098, item 5)).

Column (2) Level. This column identifies the lowest level of maintenance that requires the listed item (C = Crew, F = Maintainer).

Column (3) National Stock Number (NSN). This is the NSN assigned to the item which you can use to requisition it.

Column (4) Item Name, Description, Part Number/(CAGEC). This column provides the other information you need to identify the item. The last line below the description is the part number and the Commercial and Government Entity Code (CAGEC) (in parentheses).

Column (5) U/I. Unit of Issue (U/I) code shows the physical measurement or count of an item, such as gallon, dozen, gross, etc.

Table 1. Expendable and Durable Items List (EDIL).

(1) ITEM NO.	(2) LEVEL	(3) NATIONAL STOCK NUMBER (NSN)	(4) ITEM NAME, DESCRIPTION, PART NUMBER/(CAGEC)	(5) U/I
1	C	5350-00-221-0872	Cloth, Abrasive ANSI B74.18 (80204)	PG
2	C	7930-00-531-9716	Detergent, General Purpose MIL-D-16791 (81349)	CN
3	C	9150-00-261-8291	Grease, Plug Valve AMS-G-6032 (81343)	BX
4	C	7920-00-205-1711	Rag, Wiping 7920-00-205-1711 (80244)	BE
5	C	8030-00-543-4384	Sealing Compound AMS-S-7916 (81343)	PT
6	C	6850-00-880-7616	Silicone Compound AS86608OZTU (81343)	OZ

Table 1. Expendable and Durable Items List (EDIL) – Continued.

(1) ITEM NO.	(2) LEVEL	(3) NATIONAL STOCK NUMBER (NSN)	(4) ITEM NAME, DESCRIPTION, PART NUMBER/(CAGEC)	(5) U/I
7	C	8030-00-889-3535	Tape, Antiseizing A-A-58092 (58536)	EA
8	C	7510-00-007-4551	Tape, Pressure Sensitive Adhesive 363 (52152)	RO

END OF WORK PACKAGE

**OPERATOR AND FIELD MAINTENANCE
MANDATORY REPLACEMENT PARTS LIST (MRPL)**

INTRODUCTION

This work package includes a list of all mandatory replacement parts referenced in the task initial setups and procedures. These are items that must be replaced during maintenance whether they have failed or not. This includes items based on usage intervals such as miles, time, rounds fired, etc.

Table 1. Mandatory Replacement Parts List (MRPL).

ITEM NO.	PART NUMBER/ (CAGEC)	NATIONAL STOCK NUMBER (NSN)	NOMENCLATURE	QTY
1	G-CD-2-W (63711)	5330-00-899-4509	Gasket	8
2	G-CD-4-W (63711)	5330-00-612-2414	Gasket	12
3	ASME-B18.21.1 (05047)	5310-00-637-9541	Washer, Lock	8
4	AS29513-250 (81343)	5330-01-324-5262	O-Ring	2
5	AS3578-383 (81343)	5331-00-364-9862	O-Ring	1
6	7500-3-8 (83259)	5330-00-874-3744	Gasket	8
7	G11-4-W (63711)	5330-01-262-5120	Gasket	1

END OF WORK PACKAGE

RECOMMENDED CHANGES TO PUBLICATIONS AND BLANK FORMS For use of this form, see AR 25-30; the proponent agency is ODISC4.						Use Part II (reverse) for Repair Parts and Special Tool Lists (RPSTL) and Supply Catalogs/Supply Manuals (SC/SM).	DATE Date you filled out this form.
TO: <i>(Forward to proponent of publication or form) (Include ZIP Code)</i> U.S. Army TACOM Life Cycle Management Command ATTN: AMSTA-LC-LMP/TECH PUBS 1 Rock Island Arsenal, Rock Island, IL 61299-7630						FROM: <i>(Activity and location) (Include ZIP Code)</i> Your mailing address	
PART I – ALL PUBLICATIONS (EXCEPT RPSTL AND SC/SM) AND BLANK FORMS							
PUBLICATION/FORM NUMBER TM 10-5430-258-13&P						DATE 15 April 2009	Title Operator & Field Maint Manual w/RPSTL For Tank, Collapsible, Water Storage, 50,000 Gallon Model MPC-W-50K-22636
ITEM NO.	PAGE NO.	PARA-GRAPH	LINE NO. *	FIGURE NO.	TABLE NO.	RECOMMENDED CHANGES AND REASON (Provide exact wording of recommended changes, if possible).	
SAMPLE							
<i>*Reference to line numbers within the paragraph or subparagraph.</i>							
TYPED NAME, GRADE OR TITLE <i>Your Name</i>				TELEPHONE EXCHANGE/AUTOVON, PLUS EXTENSION		Signature <i>Your Signature</i>	

TO: (Forward direct to addressee listed in publication) U. S. Army TACOM Life Cycle Management Command ATTN: AMSTA-LC-LMPP/TECH PUBS 1 Rock Island Arsenal, Rock Island, IL 61299-7630	FROM: (Activity and location) (Include ZIP Code) Your address	DATE Date you filled out this form
--	---	--

PART II – REPAIR PARTS AND SPECIAL TOOL LISTS AND SUPPLY CATALOGS/SUPPLY MANUALS

PUBLICATION NUMBER TM 10-5430-258-13&P	DATE 15 April 2009	TITLE Oper & Field Maint Manual W.RPSTL for Tank, Fabric, Collapsible, Water Storage, 50k Gal
--	------------------------------	---

PAGE NO.	COLM NO.	LINE NO.	NATIONAL STOCK NUMBER	REFERENCE NO.	FIGURE NO.	ITEM NO.	TOTAL NO. OF MAJOR ITEMS SUPPORTED	RECOMMENDED ACTION
<h1>SAMPLE</h1>								

PART III – REMARKS (Any general remarks or recommendations, or suggestions for improvement of publications and blank forms. Additional blank sheets may be used if more space is needed.)

TYPED NAME, GRADE OR TITLE Your Name	TELEPHONE EXCHANGE/AUTOVON, PLUS EXTENSION	SIGNATURE Your Signature
--	---	------------------------------------

RECOMMENDED CHANGES TO PUBLICATIONS AND BLANK FORMS						Use Part II (reverse) for Repair Parts and Special Tool Lists (RPSTL) and Supply Catalogs/Supply Manuals (SC/SM).	DATE
For use of this form, see AR 25-30; the proponent agency is ODISC4.							
TO: (Forward to proponent of publication or form)(Include ZIP Code)						FROM: (Activity and location) (Include ZIP Code)	
U.S. Army TACOM Life Cycle Management Command ATTN: AMSTA-LC-LMPP/TECH PUBS 1 Rock Island Arsenal, Rock Island, IL 61299-7630							
PART I – ALL PUBLICATIONS (EXCEPT RPSTL AND SC/SM) AND BLANK FORMS							
PUBLICATION/FORM NUMBER TM 10-5430-258-13&P				DATE 15 April 2009		TITLE Oper & Field Maint Manual w/RPSTL for Tank, Fabric, Collapsible Water Storage, 50K Gallon	
ITEM NO.	PAGE NO.	PARA-GRAPH	LINE NO. *	FIGURE NO.	TABLE NO.	RECOMMENDED CHANGES AND REASON (Provide exact wording of recommended changes, if possible).	
TYPED NAME, GRADE OR TITLE				*Reference to line numbers within the paragraph or subparagraph. TELEPHONE EXCHANGE/AUTOVON, PLUS EXTENSION		SIGNATURE	

TO: (Forward direct to addressee listed in publication) U. S. Army TACOM Life Cycle Management Command ATTN: AMSTA-LC-LMPP/TECH PUBS 1 Rock Island Arsenal, Rock Island, IL 61299-7630	FROM: (Activity and location) (Include ZIP Code)	DATE
--	---	-------------

PART II – REPAIR PARTS AND SPECIAL TOOL LISTS AND SUPPLY CATALOGS/SUPPLY MANUALS

PUBLICATION NUMBER TM 10-5430-258-13&P				DATE 15 April 2009			TITLE Field & Oper Maint Manual w/RPSTL\Tank, Fabric, Collapsible Water Storage, 50K Gallon	
PAGE NO.	COLM NO.	LINE NO.	NATIONAL STOCK NUMBER	REFERENCE NO.	FIGURE NO.	ITEM NO.	TOTAL NO. OF MAJOR ITEMS SUPPORTED	RECOMMENDED ACTION

PART III – REMARKS (Any general remarks or recommendations, or suggestions for improvement of publications and blank forms. Additional blank sheets may be used if more space is needed.)

TYPED NAME, GRADE OR TITLE	TELEPHONE EXCHANGE/AUTOVON, PLUS EXTENSION	SIGNATURE
----------------------------	--	-----------

RECOMMENDED CHANGES TO PUBLICATIONS AND BLANK FORMS						Use Part II (reverse) for Repair Parts and Special Tool Lists (RPSTL) and Supply Catalogs/Supply Manuals (SC/SM).	DATE
For use of this form, see AR 25-30; the proponent agency is ODISC4.							
TO: (Forward to proponent of publication or form) (Include ZIP Code) U. S. Army TACOM Life Cycle Management Command ATTN: AMSTA-LC-LMPP/TECH PUBS 1 Rock Island Arsenal, Rock Island, IL 61299-7630						FROM: (Activity and location) (Include ZIP Code)	
PUBLICATION/FORM NUMBER TM 10-5430-258-13&P						DATE 15 April 2009	TITLE Field & Maint Manual w/RPSTL for Tank, Fabric, Collapsible, Water Storage, 50K Gallon
ITEM NO.	PAGE NO.	PARA-GRAPH	LINE NO. *	FIGURE NO.	TABLE NO.	RECOMMENDED CHANGES AND REASON (Provide exact wording of recommended changes, if possible).	
<i>*Reference to line numbers within the paragraph or subparagraph.</i>							
TYPED NAME, GRADE OR TITLE				TELEPHONE EXCHANGE/AUTOVON, PLUS EXTENSION		SIGNATURE	

TO: (Forward direct to addressee listed in publication) U. S. Army TACOM Life Cycle Management Command ATTN: AMSTA-LC-LMPP/TECH PUBS 1 Rock Island Arsenal, Rock Island, IL 61299-7630	FROM: (Activity and location) (Include ZIP Code)	DATE
--	---	-------------

PART II – REPAIR PARTS AND SPECIAL TOOL LISTS AND SUPPLY CATALOGS/SUPPLY MANUALS

PUBLICATION NUMBER TM 10-5430-258-13&P				DATE 15 April 2009			TITLE Field & Maint Manual w/RPSTL Tank, Fabric, Collapsible, Water Sorage 50K Gal	
PAGE NO.	COLM NO.	LINE NO.	NATIONAL STOCK NUMBER	REFERENCE NO.	FIGURE NO.	ITEM NO.	TOTAL NO. OF MAJOR ITEMS SUPPORTED	RECOMMENDED ACTION

PART III – REMARKS *(Any general remarks or recommendations, or suggestions for improvement of publications and blank forms. Additional blank sheets may be used if more space is needed.)*

TYPED NAME, GRADE OR TITLE	TELEPHONE EXCHANGE/AUTOVON, PLUS EXTENSION	SIGNATURE
----------------------------	--	-----------

TM 10-5430-258-13&P

By Order of the Secretary of the Army:

Official:

A handwritten signature in black ink that reads "Joyce E. Morrow". The signature is written in a cursive style with a large initial "J" and "M".

JOYCE E. MORROW
*Administrative Assistant to the
Secretary of the Army*

0908404

GEORGE W. CASEY, JR.
*General, United States Army
Chief of Staff*

DISTRIBUTION: To be distributed in accordance with the initial distribution number (IDN) 256992, requirements for TM 10-5430-258-13&P.

THE METRIC SYSTEM AND EQUIVALENTS

<p>Linear Measure</p> <p>1 Centimeter = 10 Millimeters = 0.01 Meters = 0.3937 Inches 1 Meter = 100 Centimeters = 1000 Millimeters = 39.37 Inches 1 Kilometer = 1000 Meters = 0.621 Miles</p> <p>Weights</p> <p>1 Gram = 0.001 Kilograms = 1000 Milligrams = 0.035 Ounces 1 Kilogram = 1000 Grams = 2.2 Pounds 1 Metric Ton = 1000 Kilograms = 1 Megagram = 1.1 Short Tons</p> <p>Liquid Measure</p> <p>1 Milliliter = 0.001 Liters = 0.0338 Fluid Ounces 1 Liter = 1000 Milliliters = 33.82 Fluid Ounces</p>	<p>Square Measure</p> <p>1 Sq Centimeter = 100 Sq Millimeters = 0.155 Sq Inches 1 Sq Meter = 10,000 Sq Centimeters = 10.76 Sq Feet 1 Sq Kilometer = 1,000,000 Sq Meters = 0.386 Sq Miles</p> <p>Cubic Measure</p> <p>1 Cu Centimeter = 1,000 Cu Millimeters = 0.06 Cu Inches 1 Cu Meter = 1,000,000 Cu Centimeters = 35.31 Cu Feet</p> <p>Temperature</p> <p>$5/9 (^{\circ}\text{F} - 32) = ^{\circ}\text{C}$ 212° Fahrenheit is equivalent to 100° Celsius 90° Fahrenheit is equivalent to 32.2° Celsius 32° Fahrenheit is equivalent to 0° Celsius $9/5 \text{ C}^{\circ} + 32 = \text{F}^{\circ}$</p>
--	--

APPROXIMATE CONVERSION FACTORS

To Change	To	Multiply By
Inches	Centimeters	2.540
Feet	Meters	0.305
Yards	Meters	0.914
Miles	Kilometers	1.609
Sq Inches	Sq Centimeters	6.451
Sq Feet	Sq Meters	0.093
Sq Yards	Sq Meters	0.836
Sq Miles	Sq Kilometers	2.590
Acres	Sq Hectometers	0.405
Cubic Feet	Cubic Meters	0.028
Cubic Yards	Cubic Meters	0.765
Fluid Ounces	Milliliters	29.573
Pints	Liters	0.473
Quarts	Liters	0.946
Gallons	Liters	3.785
Ounces	Grams	28.349
Pounds	Kilograms	0.454
Short Tons	Metric Tons	0.907
Pound-Feet	Newton-Meters	1.356
Pounds per Sq Inch	Kilopascals	6.895
Miles per Gallon	Kilometers per Liter	0.425
Miles per Hour	Kilometers per Hour	1.609

To Change	To	Multiply By
Centimeters	Inches	0.394
Meters	Feet	3.280
Meters	Yards	1.094
Kilometers	Miles	0.621
Sq Centimeters	Sq Inches	0.155
Sq Meters	Sq Feet	10.764
Sq Meters	Sq Yards	1.196
Sq Kilometers	Sq Miles	0.386
Sq Hectometers	Acres	2.471
Cubic Meters	Cubic Feet	35.315
Cubic Meters	Cubic Yards	1.308
Milliliters	Fluid Ounces	0.034
Liters	Pints	2.113
Liters	Quarts	1.057
Liters	Gallons	0.264
Grams	Ounces	0.035
Kilograms	Pounds	2.205
Metric Tons	Short Tons	1.102
Newton-Meters	Pound-Feet	0.738
Kilopascals	Pounds per Sq Inch	0.145
Kilometers per Liter	Miles per Gallon	2.354
Kilometers per Hour	Miles per Hour	0.621

PIN: 085362-000